

BSS

The Boat Safety Scheme Essential Guide

Go boating - Stay safe



The Essential Guide, second edition, is published by the Boat Safety Scheme
First published in 2002
Second edition revised and updated, August 2005

All materials, translations and adaptations © Boat Safety Scheme
All rights reserved
ISBN 0 903218 38 0

Designed by Bite CP
Printed by Greenshires Group

Acknowledgements – Members and recent members of the Boat Safety Scheme
Technical, Advisory and Management committees; members of the Examiners
Checking Procedures working group 2004-5.

Front cover photograph: British Waterways Photo Library (Eames); Fire
extinguisher attestation marks (Ch 6): Amerex, BSS, Buildings Research
Establishment; Shore connection (Ch 4) and bubble tester (Ch 7): BSS
Illustrations developed by Bite CP

Boat Safety Scheme, Willow Grange, Church Road, Watford WD17 4QA
The Boat Safety Scheme is a project jointly sponsored by British Waterways
and the Environment Agency



BSS Essential Guide

Contents

Chapter 1: Introduction

1.1	What is the Boat Safety Scheme?	2
1.2	History	2
1.3	The current Scheme	3
1.4	The navigation authorities' legal requirements	3
1.5	The BSS Essential Guide, essential reading	6
1.6	Fitting out or making changes	6
1.7	Meeting the requirements	6
1.8	Advice checks	7
1.9	How to use the guide	7
1.10	More information	9
1.11	Where do the requirements apply?	9
1.12	Documentation	9
1.13	Scope of the BSS examination	10
1.14	Recreational Craft Directive (RCD)	10
1.15	Part-built boats	11
1.16	Buying a boat?	12
1.17	Updates to this guide?	12
1.18	Booking (an examination)	13
1.19	Preparing your boat	14
1.20	At the end of the examination	14
1.21	Warning notes and dangerous boat notifications	15
1.22	BSS contact details	16

Chapter 2: Permanently installed fuel systems and fixed engines

2.1	Fuel filling points	5
2.2	Fuel filling lines	8
2.3	Fuel tank vents	10
2.4	Fuel tank vent outlets	12
2.5	Fuel tank design and condition	14
2.6	Fuel gauges	18
2.7	Petrol fuel system electrical bonding	20
2.8	Fuel tank connections	21
2.9	Fuel tank balance pipes	23
2.10	Fuel feed, return, and on-engine lines	25
2.11	Fuel line connections	29
2.12	Fuel filters	30
2.13	Fuel shut-offs	32
2.14	Carburettors	34
2.15	Engine installation	35
2.16	Steam engines	37
2.17	LPG engines	38

Chapter 3: Electrical systems

3.1	Battery storage	3
3.2	Cable specifications and condition	6
3.3	Cable location	8
3.4	Cable connections	10
3.5	Fuses and circuit-breakers	12
3.6	Battery isolators	14
3.7	Two-wire systems	18

Chapter 4: Electrical propulsion systems

4.1	Electrically propelled boats	3
4.2	Electrical propulsion motor and controller	3
4.3	Battery charging equipment	5

Chapter 5: Outboard and portable combustion engines and portable fuel systems

5.1	Portable fuel systems	3
5.2	Portable petrol tanks	6
5.3	Spare fuel containers	9
5.4	Outboard and portable combustion engines	11
5.5	LPG-fuelled outboard propulsion engines	14

Chapter 6: Fire Extinguishing and Escape

6.1	Portable fire extinguishers	3
6.2	Fire blankets	8
6.3	Emergency escape	9

Chapter 7: Liquefied Petroleum Gas (LPG) systems

7.1	LPG cylinder storage	5
7.2	LPG cylinder locker and housing LPG-tightness	7
7.3	LPG cylinder locker drains	10
7.4	Protection of LPG cylinders and components	15
7.5	Cylinder locker openings	17
7.6	LPG system shut-off valves	18
7.7	LPG high-pressure system components	19

7.8	LPG pipework, joints and connections	23
7.9	LPG hoses and hose connections	28
7.10	Portable appliance connections	33
7.11	Appliance isolation valves	35
7.12	Testing for LPG system tightness	37

Chapter 8: Cooking, heating, refrigerating and lighting appliances

8.1	Appliance fuel and power supply	4
8.2	LPG or paraffin fridges and petrol engine boats	6
8.3	Installation of appliances in petrol engine spaces	8
8.4	Fire risks from appliance installations	9
8.5	Fire risks from appliance flues and exhausts	11
8.6	LPG catalytic heaters	12
8.7	Flame supervision devices	12
8.8	LPG appliance burner operation	13
8.9	Ventilation	15
8.10	Appliance flues	17

Chapter 9: Pollution prevention

9.1	Engine/gearbox oil leak collection	3
9.2	Sanitation system	5

Appendices:

- Further Contact Details
- Glossary



Glossary and Notes

accessible for inspection	Made available for inspection and capable of being seen and reached.
battery space or box	An enclosure specifically designed to contain the batteries only.
competent person	A person who has had relevant training and has relevant experience.
damage or deterioration	Damage or deterioration materially affecting, or likely to affect, the integrity, efficiency or operation of the item or device. [For example, a crack through the bowl of a clear bowl filter would constitute damage warranting a fail but damaged paint or a torn label on the filter would not.]
deeply pitted/ heavy corrosion	In this case, it means heavy corrosion or pitting which is judged at risk of imminent failure.
diesel	The generic name for fuel-oil, gas-oil, DERV, red-diesel, white-diesel, Bio-diesel, city diesel or similar brand names.
engine space	Space or compartment of the boat containing main or auxiliary engine(s).
interior of the vessel	Anywhere within the confines of the hull apart from: <ul style="list-style-type: none">■ those areas where the arrangements of a self draining cockpit helps prevent leaked fuel or LPG entering any space, including accommodation, engine and bilge spaces [see Checklist Item 7.1.1 for full criteria];■ open locations on deck or on a cabin roof where leaked fuel would flow directly overboard unimpeded and where any openings into any space or any source of ignition are not within one metre distance.
light manual force	The application of a minimum manual force entirely proportionate to the potential for movement of the item being checked.
lines, pipes and hoses	Line is a generic term referring to the overall facility, i.e. fuel filling line. Pipe refers to rigid metallic lines, i.e. fuel filling pipe. Hose refers to a line made of flexible material, i.e. fuel filling hose.

open vessel	A vessel in which all the accommodation is completely open to the elements.
portable appliance	An appliance that is readily removable and is designed to be installed and removed at will without the use of tools and can be installed in a variety of situations.
readily accessible	Capable of being reached for operation, inspection or maintenance without removal of any craft structure or use of any tools or removal of any item of portable equipment stowed in places intended for storage of portable equipment such as lockers, drawers or shelves.
risk	The likelihood that a hazard may occur combined with the consequences of the hazardous event.
sanitation system	A system comprising equipment designed for installation on board a vessel, to receive, retain, treat or discharge sewage, and equipment using any process to treat such sewage.
self-closing valve	A valve, which in its usual state is closed and has to be constantly operated to be open.
suitable proprietary manufacture	An item or device that is, on the face of it, manufactured for the purpose determined during the examination. [For example, a solenoid controlled valve in the LPG cylinder locker must be presumed suitable, but examiners must not accept valves marked not suitable for use with LPG or DIY arrangements with 'home-fashioned'- style linkages or exposed motors].
...-tight	(Fuel, LPG, vapour) A system or container that holds the relevant gas or liquid in its neutral state and at normal operational or designed pressures (i.e. safety margins). It does not leak, weep, seep or allow any form of escape. The term may also be applied to barriers that prevent the unwanted passage of gas or liquids as appropriate.
NOTE: Units of measurement	Imperial units are UK imperial unit conversions, or nearest approximates, to the metric standard. No US volume units are used in this Guide.

1

Introduction

The Boat Safety Scheme Essential Guide



Welcome to the second edition of the Boat Safety Scheme Essential Guide, a valuable handbook for any boater who takes safety seriously and understands the importance of properly installed and maintained boat systems.

This Guide takes you step-by-step through the Boat Safety Scheme, identifying hazards, approaches to risk-reduction techniques, the legal requirements of the navigation authorities and the best practice standards to keep you and your crew safe when aboard, or close to the boat.

We have also included information about routine safety checks that you can easily carry out yourself, booking and preparing for a BSS examination, and the national and international standards for marine installations and appliances.



1.1 What is the Boat Safety Scheme?

Boating is a relaxing, enjoyable and even addictive leisure and lifestyle pursuit. For hundreds of thousands of people each year it is a tranquil and safe activity. To help it to continue to be that, all your boat's systems need to be installed, maintained and used with safety in mind.

The Boat Safety Scheme, or BSS, works on behalf of the UK's navigation and harbour authorities to help sustain safety and promote pollution avoidance on the inland waterways in respect of boats, their installations and components. The BSS does this through advice, identification of hazards, promoting techniques to avoid risks and information gathering and research.

The navigation authorities are committed to help prevent boat fires, explosions, or pollution harming other people and property.

The Scheme reduces the risk of such incidents by using the BSS examination to verify that systems and appliances on any given boat at least meet the minimum safety requirements.

1.2 History

On inland waterways, safety requirements, some dating back to the very earliest part of the twentieth century, have been stipulated for boats following fires, explosions and other types of incident. In 1997 its current owners, the Environment Agency and British Waterways, established the BSS to set a common and specific list of safety standards for boats, their systems, installations and appliances.

Following an independent review of the Scheme in 2001, the full set of BSS Standards was split into essential safety/environmental requirements and best safety-practice recommendations.

1.3 The current Scheme

Today, the BSS is much more than an examination. Education, persuasion and promotion of safety is equally important, perhaps even more so as there are hazards and risks linked to the use of fuels and appliances even when the boat itself is in safe condition. Now the navigation authorities have asked the BSS to promote advice to help maintain and improve the quality of the water of inland navigations.

1.4 The navigation authorities' legal requirements

There are 31 legal requirements listed below for privately-owned and privately-managed boats. These requirements, known as the BSS General Requirements, are expressed in goal-setting terms. They are supported by expected means of compliance that are set out in Chapters 2 to 9 of this Guide.

Permanently installed fuel systems and fixed engines

- 1 All permanently installed fuel systems and fixed engines must be designed, installed and maintained in a way that minimises the risks of explosion, or of fire starting or spreading.

- 2 Fuel filling arrangements must prevent any overflow from entering the interior of the vessel.

- 3 All fuel filling points must clearly identify the fuel in use.

- 4 Marking must be provided to identify the location of fuel system emergency shut-off devices, or their means of operation, which are not in open view.

- 5 All permanently installed fuel systems must be designed, installed and maintained to ensure fuel-tight integrity.

- 6 All permanently installed fuel tanks and fuel system connections must be accessible for inspection.

- 7 The pressure systems of steam-powered installations must have a current inspection certificate issued by a recognised competent person.

The navigation authorities' legal requirements (continued)

Electrical systems

- 8 All electrical systems must be designed, installed and maintained in a way that minimises the risks of explosion or of fire starting and spreading.

- 9 All electrical systems must be capable of being safely and quickly disconnected from their power source(s) in an emergency.

- 10 Control and emergency devices, or their means of operation, must be marked when not in clear view, or when their function is not clear.

- 11 All battery compartments containing unsealed or open-vented batteries must be adequately ventilated to prevent a build-up of a flammable mix of gases.

Electrical propulsion systems

- 12 All motors, controller equipment and charging equipment relating to electrical propulsion must be adequately ventilated.

Outboard and portable combustion engines and portable fuel systems

- 13 All portable and outboard engines and portable fuel systems must be designed, installed and maintained in a way that minimises the risks of explosion, or of fire starting and spreading.

- 14 All spare petrol must be stored in a way that minimises the risk of fire and explosion.

- 15 All portable and outboard engines with integral petrol or LPG tanks, and all portable petrol tanks, must be stored in a way that minimises the risks of fire, or explosion when not in use.

Fire extinguishing and escape

- 16 All vessels must carry specified fire-fighting equipment.

- 17 All fire-fighting equipment must be in good condition and kept readily accessible for safe use in an emergency.

LPG systems

- 18 All LPG systems must be designed, installed and maintained in a way that minimises the risks of explosion, or of fire starting and spreading.
-

- 19** All LPG containers and high-pressure components must be secured in a position where escaping gas does not enter the interior of the vessel.
-
- 20** All LPG systems must be designed, installed and maintained to ensure gas-tight integrity.
-
- 21** All LPG system connections and flexible hoses must be accessible for inspection.
-
- 22** All LPG control and shut-off devices, or the means to operate them must be readily accessible.
-
- 23** LPG shut-off valves, or their means of operation, must be marked when not in clear view, or when their function is not clear.
-
- 24** All LPG systems must have a suitable means to test that the system is gas-tight.
-

Appliances and flues

- 25** All appliances must be designed, installed and maintained in a way that minimises the risks of explosion, or of fire starting and spreading.
-
- 26** All liquid-fuelled appliances must have an emergency shut-off valve located at a safe distance from the appliance.
-
- 27** a) **LPG and liquid-fuel burning appliances installed from 3 Jan 2000** All burners and pilot lights shall be fitted with a device that automatically shuts off the fuel supply if the burner flame fails.
-
- b) **LPG and liquid-fuel burning appliances installed before 3 Jan 2000** Burners on catalytic appliances, appliances with continuously-burning flames and pilot light burners shall be fitted with a device that automatically shuts off the fuel supply if the burner flame fails.
-
- 28** All appliance flues must be designed, installed and maintained in a way that minimises the risk of fire.
-
- 29** All fuel and power supply systems for appliances must meet these navigation authority requirements where relevant.
-

Pollution prevention

- 30** Any leakage of oil from engine equipment must be contained and prevented from being avoidably discharged overboard.
-
- 31** Bilge pumping and toilet systems must be designed, installed and maintained in a way that minimises the risk of avoidable pollution.
-

1.5

The BSS Essential Guide and why it's essential reading

Carrying out routine maintenance is highly recommended, as is using this Guide to check that the boat still complies with the BSS General Requirements, especially when making alterations or additions.

Making time to read the Guide will pay dividends, both before booking your BSS examination and when preparing your boat for examination. The information in this Guide about the compliance options is exactly the same information as authorised examiners use to carry out a BSS examination.

For these reasons, it has been designed as a companion publication for you to keep on board for quick and easy reference.

1.6

Fitting out or making changes

It is important to remember that this Guide is not a DIY instruction manual on boat construction, repairs or maintenance. You should always refer to a manufacturer or supplier for such information. We also recommend having a competent person replace, modify or repair any part of your boat's installations, components and appliances.

Before making changes to your boat, check the latest editions of relevant British and International Standards as well as marine or other relevant industry codes of practice. There are references to some relevant ones in each chapter and useful sources of information in the contact list.

1.7

Meeting the requirements

The compliance checks in the Guide were devised with the help of the BSS committees. They form our expectations of how a boat will meet the General Requirements.

Checking that your boat meets these expectations will probably mean that at the time of examination, a certificate can be issued without delay. If however, an installation on your boat does not match the expectations set out in the Guide, then you have four options:

- a) Seek guidance from the BSS Office that you are interpreting the published check and guidance in the way the Scheme originally envisaged, or;
- b) make alterations to the installation, system or appliance so that it meets the expectation(s), or;
- c) contact the BSS Office directly with documentary evidence that it still complies with the relevant BSS General Requirement(s). An assessment and judgement will be made within a very short time of having all the evidence for appreciation, or;

- d) if at this stage, the BSS Office is still of a view that the navigation authorities' requirements are not complied with, you will be allowed to present the evidence to a formal appeals process.

Please note this important point: your examiner must not offer a judgement of compliance outside of the actions and notes of the checks published in this Guide, unless he or she has had specific guidance from the BSS Office. Please do not ask the examiner to act on a discretionary basis and please report to the BSS Office any examiner you believe may be doing so.

1.8 Advice checks - safer than the minimum requirements

During the BSS examination, the examiner will also check a number of items not linked to the enforceable navigation authorities' requirements. These advice checks are just that: good advice that will help you keep the people onboard your boat safe! Although privately-owned boats do not have to comply with any of these to be issued a certificate, each advice check represents best-safety practice. We recommend that your boat meets all of these points. You can then be confident that as an owner, you have achieved a higher standard of safety.

1.9 How to use the guide

Beyond the introduction, this Guide is divided into eight chapters describing the compliance expectations in detail. The introduction to each chapter explains in general terms what risks are associated with that particular area of your boat and then lists again the related BSS General Requirements.

A short note on the nature of the fuel for instance, or of the risk subject of the chapter may follow. These notes offer the background information to understand better the reasons behind the Requirements and how they are supported by the compliance checks. The compliance checks are next. These are grouped into sections. There is a short introduction to the key points covered in the section followed by the details of checks and options. Most checks are also preceded by a short description of the hazard or risk being addressed. In setting out the Guide in this way, our aim is to highlight specific risks and the means to minimise them, along with practical illustrations of how to comply with the requirements. The requirements to protect others from fire, explosion and pollution are clearly distinguished from advice checks and the recommendations for the additional safety of you and your crew.

Here is an example of the information within the Guide:

2.6 Fuel gauges

section reference and title

An inappropriately installed gauge on your tank could introduce a serious weakness

generic risk description

Glass or plastic fuel sight-tube gauges can easily be damaged by knocks or the heat from a fire leading to a catastrophic leak of the tank contents. With diesel or paraffin tanks, limiting any potential fuel escape is key to maintaining protection.

specific risk description

2.6.1/R REQUIREMENT

Are any glass or plastic tube or strip-type fuel gauges fitted to diesel tanks only?

Check each petrol tank for glass or plastic tube or strip-type fuel gauges.

Petrol tanks must not be fitted with glass or plastic fuel gauges.

When carrying out your own routine examination, answering 'yes' to each appropriate compliance check will give you confidence that your boat meets the expectations. Where they exist, the notes will help you make an accurate assessment. See the example below associated with 3.1.3/R Are battery terminals correctly insulated or protected?

Notes - deck boards, locker lids, etc, made from or lined with insulating material may only be considered as battery covers where they will not be removed for any purpose other than gaining access to the batteries.

The number is the reference R (red) shows it is a requirement. An A (grey) would show it is an advice check.

The question forms the compliance check (red or grey box).

It is followed by the description of the checking action i.e. when the check applies; when it does not; what it applies to; how it applies (blue box).

This is supported by the details of the check criteria and specific requirements when appropriate. These clarify whether the checked item complies or not (yellow box).

Occasionally a compliance check, with or without notes, is followed by another box that may contain advice on industry best practice, installation advice, etc. It is our recommendation for greater safety to supplement that section's expectations. Often this is where the requirement is for historically lower standards than what the industry codes currently stipulate or where we have previously published best practice which continues to be valuable, for example, from the gas section Chapters 7 and 8.

Best practice

Regulators have a finite life and we recommend that, in general, they are replaced at least every 10 years.

**Information**

There are additional handy tips and further information from the BSS Office and examiners shown in information boxes like this.



1.10 More information

You can find out more information by speaking with your local examiner or contacting the Boat Safety Scheme Office (01923 201278). Further advice if you are unsure about anything connected with the navigation authorities' requirements or the safe use of fuels, installations and appliances is available on www.boatsafetyscheme.com and related links from the site.

1.11 Where do the requirements apply?

The Boat Safety Scheme has been endorsed by all the UK navigation authorities, represented by the Association of Inland Navigation Authorities (AINA) and it is a good idea to contact your local navigation authority to see if the BSS applies and whether any other regulations are in force. Some harbour authorities and private marinas also use the BSS.

All licensing and registration queries should be directed to your appropriate navigation or harbour authority. Contact details for some authorities and other useful sources of information are listed at the end of this Guide.

1.12 Documentation

There is also a clear plastic wallet included in the Guide where you can keep your certificate and other useful paperwork connected with the safety of your boat. Keeping such documents could be important, for example, invoices for replacement parts or work you may have had done to your boat could be used to help decide its compliance.

This type of documentation is also handy if you are thinking about selling the boat as a prospective buyer will recognise the care you have taken when it comes to ensuring safety.

1.13 Do the requirements apply to my craft? (scope)

- All vessels carrying fuel or fitted with domestic cooking, heating, refrigerating or lighting appliances are required to undergo a BSS examination except for those craft covered by an RCD Declaration of Conformity (see 1.14).
- A vessel for which there is in force a valid Passenger Certificate issued under the Merchant Shipping Regulations is considered by some navigation authorities, as meeting their legal requirements.
- A BSS examination is not required in respect of any privately-owned, open vessel (i.e. a vessel in which all the accommodation is completely open to the elements) if it has no domestic cooking, heating, refrigerating or lighting appliances installed and it is propelled solely by an outboard engine. Please note, such boats remain subject to all appropriate navigation authorities' legal requirements.
- Some navigation authorities may allow vessels a short-term or visitor status licence or registration without the need to undergo a BSS examination on the basis that the owner makes a declaration that his or her vessel meets the navigation authorities' legal requirements outlined in this Guide and is willing to allow spot checks by navigation authority officers or authorised agents for the authority. Such boats remain subject to all appropriate navigation authorities' legal requirements.

1.14 Notes on the Recreational Craft Directive (RCD)

CE-marked craft conforming to the Recreational Craft Directive (RCD) are considered by some navigation authorities to have met their requirements for the first four years from new. Owners can usually make a licensing or registration application with a suitable Declaration of Conformity (DoC) supplied by the boat's builder.

In the UK the RCD is transposed into UK law by way of the Recreational Craft Regulations (RCR).

Technical equivalence with the RCD

The last thorough review of the BSS requirements included a comparison with the RCD. The aim was to ensure either alignment with, or, that the BSS requirements do not exceed the demands of the RCD.

To ensure this aim continues to be met, the BSS has available a Technical Equivalence Panel of three independent experts who will offer their guidance on the equivalence of systems or components on CE-marked craft in the circumstances where the item or component fails a BSS examination and an appeal is presented by the owner or supplier.

1.15 Part-built boats

If you have bought a shell or 'sailaway', or any other partly completed boat as defined by the RCD, you should have received from the builder an Annex IIIa Declaration. This is an important document and by providing it the builder is meeting his obligation under the RCD and declaring that the boat is for completion by others and at the stage of completion at handover it complied with the applicable essential requirements of the RCD.

A suitable builder's Annex IIIa Declaration is accepted in support of the first licence or registration application by some navigation authorities. Ordinarily owners of such craft will need to produce either a valid certificate issued by a BSS examiner or a full RCD Annex XV Declaration of Conformity for the completed boat in support of the next annual licence application.

There is an information sheet for owners of recently purchased shells, 'sailaways' or other types of partly completed boat available on www.boatsafetyscheme.com or from the BSS Office by post.

Further information about the RCD is available from the British Marine Federation (BMF) (www.britishmarine.co.uk - click on 'publications' then 'technical') or the Royal Yachting Association (www.rya.org.uk - search on 'Technical').

1.16 Buying a boat?

When a certificate is issued, it relates only to the observations recorded at the time of the examination and does not guarantee that a boat complies at any other time since maintenance could have been lacking or new appliances installed below minimum standards. Furthermore, there are important aspects of safe boating that are not addressed in a BSS examination; for example, the BSS examination is not a full survey and does not cover the condition of the hull or deck, the integrity of through-hull fittings or the stability of the boat.

If you are thinking of buying a boat, we strongly advise you to commission a full condition survey before committing yourself to buy it. Satisfy yourself that the boat complies not just with the minimum safety requirements of the navigation authorities, but in many or all respects that it meets the standards of best practice to keep you and your crew safe.

1.17 Updates to this guide?

The Guide has been designed so that it can be updated quickly and easily if the need arises. On each page there is the reference that will allow you to insert an update and remove redundant pages without disrupting the rest of the Guide. Look out for news from the navigation or harbour authorities and articles in the waterways press and websites such as www.waterscape.com or www.boatsafetyscheme.com for news of updates.

Your boat's BSS examination

1.18 Booking

You can book an examination up to two months before your old certificate or RCD Declaration of Conformity 4-year deadline runs out. If your boat passes first time, the examiner will post-date the new certificate to start from the date when the old one or DoC expires. This means you do not lose any of the full four-year validity of the certificate.

We recommend taking advantage of this facility, because if your boat fails for any reason, you will still have some time to put things right.

For the same reason even if you have no old certificate or DoC it is a good idea to contact an examiner well in advance of needing to get your boat licensed, registered or take up a mooring.

Finding an examiner is usually quite easy, and there are a number of ways you can do this. You can generate a list of examiners by accessing www.boatsafetyscheme.com. The BSS Office and some local navigation authority offices can also supply tailored lists. The main waterways' magazines often publish details of examiners, or you might like to ask fellow boaters for recommendations.

Be prepared to get two or three quotations, and always have a list of questions to hand so that you can agree the details right at the outset. These could include for example, does the price include the cost of a certificate, are there extra charges if the examiner spends longer inspecting your boat than he expected, and will there be an extra charge if the examiner needs to make a return visit? The examiner might ask you a range of questions about the systems installed on your boat to help him give you an accurate quote. Sorting these details out can help you make an informed choice when selecting an examiner.

Remember, each examiner is free to set his or her own charges, and market forces, the complexity of the boat's installations, VAT applicability, and travelling time will probably influence the prices given to you.

1.19 Preparing your boat

Regular maintenance to keep your boat safe and complying with the legal obligations when it is on the water should ensure a first-time pass. However, preparing your boat before its examination will pay off. Apart from checking to see that installations, components and fittings comply with the requirements before the examiner arrives, there are several things you can do to make the whole process run smoothly.

All required items must be capable of being checked effectively and accurately. If not, the examination will be considered to be incomplete. An examiner cannot issue a certificate on an incomplete examination, so here are a few points to keep in mind.

- Ensure that all the boat's installations and appliances are fully functional so that a complete examination can take place. This includes having a fully charged battery and sufficient gas and water, together with any other documentation that shows compliance with the BSS General Requirements.
- If the good condition or suitability of any item cannot be verified where this is a requirement, no certificate will be issued. Ensure full access to all gas joints and as much pipework as possible for a thorough examination. Items such as gas lockers should be unlocked, and boards and panels removed to give access where verification is necessary.
- Notify any relevant landowners who may have to give access to the examiner so that he can get to your boat's mooring.
- Have the existing certificate to hand. This will help the examiner with information about the boat that he or she must record, such as when it was constructed, and with the confirmation of the expiry date of your current certificate.

1.20 At the end of the examination

The examiner must issue you with a BSS Examination Report form after the first examination is completed.

If your boat fails on any of the checks the examiner carries out, whether they are related to the BSS General Requirements, or to advice checks, the report will explain which were not compliant or unable to be verified as compliant.

The examiner may supplement this information, typically using BSS Form E or using his/her own headed business paper/forms.

Your boat will still be eligible for a certification if your boat only meets the BSS General Requirements, although complying with the advice checks may give you further peace of mind and help you to meet some of your responsibilities to your crew or visitors.

You will get two copies of the certificate dated accordingly. It is the confirmation that your boat has been examined by the examiner against the BSS compliance checks and on the day of examination complied with the navigation authorities' legal requirements. It is important to keep the top copy with the hologram safe and pass it onto the new owner should the boat change hands.

The second copy, which is blue, may be requested by your navigation or harbour authority for checking or retention, as a part of your licence, registration, or mooring application.

On issuing the certificate, the examiner will record some detail of the boat including the appliances. Keep your copy of this safe too, preferably with the new certificate as it could qualify some of the information on the certificate.

Please remember, if your boat is found not to comply with the BSS General Requirements and your boat is on a waterway where there is a legal basis for them, you will either have to bring it up to standard or present reliable documentary evidence supporting a claim of compliance with them.

1.21 **Warning notices and dangerous boat notifications**

Warning notices

In circumstances which are described in the notes section of some of the compliance checks, your examiner may issue your boat with a warning notice. These are issued for two purposes, firstly to alert the owner or person responsible for the craft's condition that a serious and immediately hazardous defect has been found. Secondly, to alert anyone stepping aboard that they could be at risk and should take precautions.

The examiner will have made a brief note about what the defect is. For further information please contact the examiner.

What it means / what to do now?

You must now consider yourself duly alerted to the hazardous defects. Where they relate to BSS General Requirements, your navigation authority will insist that repairs are made as soon as possible.

Who has been told?

This note has been sent or handed to you and a copy has been displayed on the boat in a prominent position. BSS examiners will keep another copy in their records about this vessel.

Dangerous boat information

Where the defects relate to the following hazards further action may be taken:

- Leaking gas
- Leaking fuel
- Gas refrigerators with naked flames on petrol-powered boats
- Significant quantities of fuel or other substances escaping into the watercourse.

The examiner will ask you to make the boat safe immediately and not to use the vessel/appliance until the defects have been properly fixed. The examiner is also required to inform the owner of the moorings and the BSS Office who will alert the appropriate navigation or harbour authority.

UK Law

It may be an offence under the Gas Safety (Installation and Use) Regulations for a person to use or permit a gas installation/appliance to be used that might constitute a danger to any person or property. In the event of injury or damage to property, the existence of known defects may be material to the boat owner's duties under the law of occupier's liability or to the boat owner's insurance.

Finally

We trust you will find the following chapters a useful and comprehensive reference to help maintain your boat in a safe and legal condition. If anything is unclear or if you need any support and advice about the examination or compliance options, please contact the BSS Office using the following details:

BSS Office	Phone: 01923 201278
Willow Grange	Fax: 01923 201420
Church Road	Email: bss.enquiries@boatsafetyscheme.com
Watford WD17 4QA	Web: www.boatsafetyscheme.com

2

Fixed fuel systems and permanently installed engines

The Boat Safety Scheme Essential Guide



For more technical information

The requirements in this chapter have been informed by, and may refer to, the following technical references, codes and regulations. If you are building, fitting-out or making substantial changes to a vessel, we strongly recommend you refer to, and take account of, the codes and standards below:

- **BS EN ISO 7840:2004** 'Small craft. Fire-resistant fuel hoses'
- **BS EN ISO 10088:2001** 'Small craft. Permanently installed fuel systems and fixed fuel tanks'
- **BS EN ISO 15584:2001** 'Small craft. Inboard petrol engines. Engine-mounted fuel and electrical components'
- **BS EN ISO 16147:2002** 'Small craft. Inboard diesel engines. Engine-mounted fuel and electrical components'
- **DIN 4798:1988** 'Hosepipes for extra-light fuel oil; safety requirements, testing, marking'
- **LP Gas Association Code of Practice 18** 'Recommendations for the safe use of LPG as a propulsion fuel for boats, yachts and other craft'
- **SAE J1527:2004** 'Marine Fuel Hoses'



Fixed fuel systems and permanently installed engines

The watertight nature of boats means that they also act as good containers for leaks or overflows of flammable liquids and vapours!

Stored fuels such as diesel or petrol in confined and undrained spaces carry the risk of providing fuel for a fire or explosion. This chapter covers the need to keep fuel away from sources of ignition for as long as possible.

It also covers why the fuel filling and fuel supply arrangements must not allow leaks to accumulate inside the confines of your boat. Thus, all fuel system components must be in good condition. They must also be fire resistant, suitable for the fuel being used and kept away or shielded from sources of heat.

To avoid pollution, spilt fuel oils are normally prevented from being discharged into the waterway and the detail of prevention is in Chapter 9. However, the overriding need to minimise the risk of fires, spread of fire and explosions, means that small amounts of overflowing fuel are better directed overboard than allowed to flow into the craft interior.

These requirements and checks apply to all boats with inboard engines and to other fixed fuel systems supplying liquid-fuelled appliances such as diesel heaters. Further requirements relating to appliances and their installation and maintenance are in Chapter 8.

If you carry spare fuel in portable containers, the requirements related to the safe type and location of spare fuel containers is covered in Chapter 5.

Boats obliged to meet BSS requirements must comply with the following:

- 1** All permanently installed fuel systems and fixed engines must be designed, installed and maintained in a way that minimises the risks of explosion, or of fire starting or spreading.
- 2** Fuel filling arrangements must prevent any overflow from entering the interior of the vessel.

- 3** All fuel filling points must clearly identify the fuel in use.

- 4** Marking must be provided to identify the location of fuel system emergency shut-off devices, or their means of operation, which are not in open view.

- 5** All permanently installed fuel systems must be designed, installed and maintained to ensure fuel-tight integrity.

- 6** All permanently installed fuel tanks and fuel system connections must be accessible for inspection.

- 7** The pressure systems of steam-powered installations must have a current inspection certificate issued by a recognised competent person.

An important preface on the nature of ...

... petrol

Petrol is very volatile, that is, it evaporates quickly generating highly flammable vapours. A small spill of petrol will create a large amount of vapour. Likewise, when it is being transferred and especially when a tank is being filled and the vapour in the 'empty' tank is displaced by the liquid fuel. Even if the concentration of vapour is too rich to burn immediately, it will dilute to flammable or explosive levels, even though given enough ventilation, it may dissipate to a safe level eventually.

Petrol vapour is three to four times heavier than air. It will sink to the lowest level of its surroundings, accumulating at low level in places such as unventilated lockers and bilges or in enclosed spaces such as the cabins and cockpits of boats.

...diesel

As with petrol, diesel as a liquid does not burn, but when it is heated, the vapour given off is combustible and will burn strongly. To reach this stage, termed the flash point, diesel fuel only needs to be heated to around 56°C and this can be lower in winter due to the anti-waxing additives.

Diesel can be raised to flash point temperature by contact with gas flames, frictional sparks, electric sparks, and small fires as well as other heat sources.

Diesel fuel will ignite readily; materials soaked through with diesel and acting as a wick, greatly assist the spread of an established fire. Once alight, diesel burns with great heat and strength. **[based on information in the Library of Fire Safety, Vol. 2, Fire Protection Association,]**

Information

If a small amount of fuel escapes overboard, through measures designed to lower fire risks, it will be diluted naturally. If large quantities of fuel or other substances escape into a waterway you should contact the Environment Agency/Scottish Environment Protection Agency Pollution Hotline on 0800 80 70 60 (24hrs).

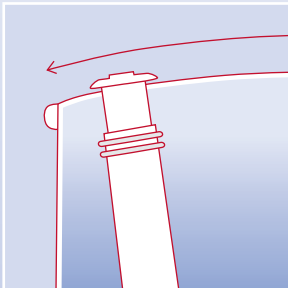

Sloped Deck

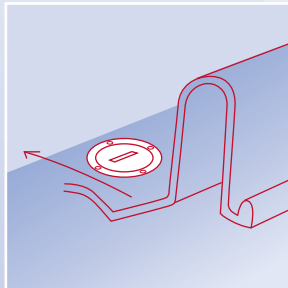

High Coaming

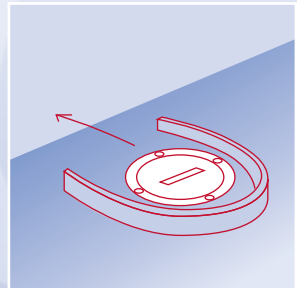

Diverter Arrangement

2.1 Fuel filling points

Whether the cause is overfilling, blockages, restrictions or blow-backs, there is a risk that fuel could find its way into the interior of the boat if its fuel-filling points have no means of preventing this.

A small amount of leaked fuel can contribute to the cause or a spread of a fire. Leaked petrol could cause an explosion. This is the risk being addressed in this section.

2.1.1/R REQUIREMENT

Does the location of the fuel filling point ensure that any fuel overflow is prevented from entering the interior of the vessel?

Check the location of fuel filling points and assess the potential for any overflowing fuel to enter the interior of the vessel.

Fuel overflowing from filling points must be prevented from entering any part of the interior of the vessel. Accordingly, fuel filling points must be positioned so that...

- the camber or configuration of the deck; or,
 - the boat's coaming; or,
 - a diverter arrangement;
- ...causes any overflow to discharge overboard.

Notes – This requirement does not apply to the following provided there is no risk of unseen spillage:

- historic (i.e. bone fide ex-working boat) diesel-engined narrowboats;
- diesel tanks, of up to a maximum capacity of 271 (6gal)

Open vessels, such as RIBs (Rigid Inflatable Boats) with a continuous deck or sole that is fuel tight to the interior of the vessel and bilge spaces, meet this requirement.

Diesel fuel fillers onto self-draining cockpits meet this requirement if they have...

- a continuous deck or sole; **and**,
- drain outlets above the normal laden waterline; **and**,
- are fuel tight to the interior of the vessel, including bilge spaces.

Preventing cross-contamination between different fuels, water and other liquids or spills into the hull is being addressed here. If fuel is poured down the wrong deck connection, there is a risk of a fire, explosion, or a pollution incident. It may also be expensive and time-consuming for the owner to remedy.

2.1.2/R REQUIREMENT

Is the fuel in use correctly and clearly marked on or adjacent to the fuel filling point?

Check for markings on or adjacent to fuel filling points.

The specific fuel type in use must be correctly and clearly marked on or adjacent to all fuel filling points:

- 'DIESEL'; or 'FUEL OIL', or 'GAS OIL', or 'DERV', or 'BIODESEL'; or,
- 'PETROL', or 'GASOLINE'; or;
- 'LPG BUTANE/PROPANE' as appropriate; or,
- 'PARAFFIN'; or,
- 'PETROIL'.

Notes – The use of embossed tape (e.g. Dymo) or other lettering that can become illegible through cleaning or normal use is not acceptable. The marking must be legible with all lettering complete.

Marking fuel filling points solely with 'fuel' or 'gas' is not acceptable.

Marking fuel filling points with the internationally accepted symbol or the fuel in use is acceptable. The BSS Office can be contacted for guidance as to a symbol's compliance with the requirements.

Best practice

We recommend that other disused deck connections, if not blanked off, also be marked clearly to prevent cross-contamination and spillage.

b

2.1.3/R REQUIREMENT**Are all disused fuel filling points disabled?**

Check all fuel filling points and other deck connections.

Identify any that are marked as fuel filling points, or that may be taken to be fuel filling points, but are no longer connected to a fuel tank.

Check for signs of disabling.

Unused fuel filling points must be permanently disabled to such an extent that it would require the use of tools to remove the disabling method.

Note – The use of a suitable proprietary adhesive to secure filling point caps or plugs in place etc. meets this requirement.

Having the right diameter line will help make sure that any fuel-filling nozzle is properly inserted and will help prevent ‘blow back’ of fuel when refuelling.

2.1.4/R REQUIREMENT**Is the internal diameter of the fuel filling point at least 31.5mm (1¼ in)?**

Measure the internal diameter of each fuel filling point.

Fuel filling points must have a minimum internal diameter of 31.5mm (1¼ in).

Note – If it is not practicable to measure the internal diameter at fuel filling points, an estimate based upon the external diameter of the fuel filling line can be made.

Information

Do not use metallic measuring tools on metallic petrol filling points, they may cause sparks and ignite the petrol vapour.



2.2 Fuel filling lines

These lines need to be able to carry fuel effectively without any leaks, risks of leaks, overflows, or spills. With fuel filling lines that are located out of sight, leaks or material failure can go unnoticed unless regular checks are made.

Ineffective fuel connections will leak with the potential for causing fire and explosion or adding to the intensity of a fire and then it spreading.

2.2.1/R REQUIREMENT

Are the fuel-filling line connections leak free and in good condition, and are all fuel-filling hose connections accessible for inspection?

Check for the presence of fuel filling hose connections, and the condition by sight and touch.

Check the condition of fuel filling pipe connections where they can be seen or reached.

All fuel-filling hose connections must be accessible for inspection, and must be secure and free of leaks, signs of damage and/or deterioration.

Fuel filling pipe connections must be secure and free of leaks, signs of damage and/or deterioration.

Note – If inaccessibility of any connection prevents it from being verified as leak free and in good condition, it will be considered as non-compliant until its good condition has been verified.

Best practice

Inspect the connections routinely. Check the condition of hose clamps that are used to make joints. Replace them on inspection if they or the hose appear damaged, cracked, worn, or corroded.

We recommend the use of double clamps on a filling hose used for petrol.

We recommend that the fuel filling line is as short as practicable.

Supporting long lengths of hose at regular intervals may help prevent abrasion damage against interior fittings and extend the useful life of the hose.

b

Fuel must not be retained in the filling hose, as this could cause blow back when refuelling.

2.2.2/R REQUIREMENT

Is the fuel filling line self-draining so that fuel is not retained and is it free of kinks or other restrictions?

Check the fall of each fuel filling line.

Check for any kinks or other obvious restrictions in fuel filling lines where they can be seen or reached.

Fuel filling lines must be 'self-draining' i.e. fall continuously from the filling point to the fuel tank connection so that fuel is not retained.

Fuel filling lines must not be kinked or restricted.

Note – Fuel filling lines must not have their internal bore diameter restricted to less than 31.5mm (1¼ in).

Damaged or deteriorating fuel filling lines could fail and result in a leak that could form a potential fire, explosion, or pollution hazard depending on the fuel used. In the case of petrol, hose not designed specifically for that fuel can fail rapidly. Indeed all fuel oils can 'attack' unsuitable materials.

2.2.3/R REQUIREMENT

Is the material of the fuel filling line suitable and in good condition?

Check the material and condition of fuel filling lines, which can be seen or reached.

Check the markings on any fuel filling hose.

Fuel filling lines must not show signs of fuel leaks, damage, or deterioration.

Fuel filling hose must be marked as suitable for the fuel in use or supported by an appropriate declaration.

Notes – diesel filling hose in good condition may be accepted without marking or declaration provided it can be examined over its entire length.

Enough suitably marked diesel filling hose, or enough petrol hose, must be accessible to make a reasonable assessment as to the hose's general condition.

Best practice

We recommend that you use hoses marked with BS EN ISO 7840 although hoses marked with SAE J 1527, DIN 4798 or marked with the type of fuel in use are acceptable.

b

2.3 Fuel tank vents

Potentially dangerous and polluting fuel blow-backs are known to happen during refilling. The tank also needs to be able to 'breathe' to help the supply of fuel to the engine or appliance. Temperature changes cause the volume of fuel to expand and contract.

Venting needs to be effective at all levels of fuel in the tank. A vent line can also be a filling line, or an overflow line, and the requirement for a vent does not apply to small auxiliary tanks with a vented filling cap on the tank.

2.3.1/R REQUIREMENT

Does every fuel tank have an effective vent facility?

Check all fuel tanks for the provision of a vent facility.

A vent line must be fitted to the top of each fuel tank, or a vent must be fitted to either the filling cap, or filling line.

Note – Vents in the filling cap or filling line must have their outlet at or above filling point level.

2.3.2/R REQUIREMENT

Does the fuel tank vent line have a minimum internal diameter of 9.5mm?

Measure the outside diameter of fuel vent lines.

The internal diameter of vent lines must be at least 9.5mm ($\frac{3}{8}$ in).

Notes – The internal diameter may be verified by measuring the outside diameter and estimating wall thickness. The following are approximate indications, copper 11.5mm ($\frac{1}{2}$ in), steel 12.5mm ($\frac{1}{2}$ in), hose 15.5mm ($\frac{5}{8}$ in).

The hole in the filler cap of small capacity tanks of no more than 27 litres is deemed to meet this requirement. Examples include those found on Stuart Turner petrol tanks, Yanmar engines' close-coupled tanks or diesel tanks supplying appliances.

Best practice

We recommend fitting a vent line of at least 12mm (1/2 in) internal diameter fitted which meets with international standards.

b

2.3.3/R REQUIREMENT**Are the fuel tank vent line connections leak free and in good condition?**

Check the condition of fuel tank vent line connections where they can be seen or reached.

Vent line connections must be secure and free of leaks, signs of damage or deterioration.

If a vent line retains fuel, it could leak or stop the vent from working.

2.3.4/R REQUIREMENT**Is the fuel tank vent line self-draining so that fuel is not retained, and is it free of kinks or other restrictions?**

Check the fall of each vent line.

Check for any kinks or other obvious restrictions in any vent lines where it can be seen or reached.

Vent lines must be connected to the top of the tank and be 'self-draining', i.e. fall continuously from the vent outlet to the tank, or, where a swan neck is installed, from the top of the swan neck down to the vent outlet and the fuel tank connection.

Vent lines must not be kinked or restricted.

Notes – vent lines must not have their internal bore diameter restricted to less than 9.5mm (3/8 in).

'Top of the tank means the top plate of the fuel tank or the highest part of the side of the tank.

Best practice

We recommend that you use hoses marked with BS EN ISO 7840 although hoses marked with SAE J 1527, DIN 4798 or marked with the type of fuel in use are acceptable.

b

2.3.5/R REQUIREMENT

Is the material of the fuel tank vent line suitable and in good condition?

Check the material and condition of vent lines, which can be seen or reached.

Check the markings on any vent hose.

Vent lines must not show signs of fuel leaks, damage, or deterioration.

Vent hose must be marked as suitable for the fuel in use or supported by an appropriate declaration.

Notes – Diesel tank vent hose in good condition may be accepted without marking or declaration provided it can be examined over its entire length.

If suitably marked, enough vent hose must be accessible to make a reasonable assessment as to the hose's general condition.

2.4 Fuel tank vent outlets

There is a risk of pollution, fire or explosion if fuel flows out of a vent outlet on an overfilled fuel tank.

2.4.1/R REQUIREMENT

Does the fuel tank vent outlet, or the vent line swan neck, rise at least as high as the filling point?

Check the rise of each vent line.

Fuel tank vent outlets or the vent line swan neck must rise to a height at least that of the fuel filling point.

Note – where the filling point is mounted on a deck a swan neck in the vent line to the underside of the deck meets this requirement.

Fuel vapours exhaust from the vent. If ignited, a flame close to, or at the end of, the vent line, has the potential to flash back into the fuel tank. An unprotected vent outlet could become blocked by debris or insects, etc.

2.4.2/R REQUIREMENT

Is the fuel tank vent outlet fitted with an effective flame arrester or flame-arresting gauze?

Check each vent outlet for the presence of a flame arrester or flame-arresting gauze.

Vent outlets must be fitted with either a suitable proprietary flame arrester or gauze of at least 11 wires per linear cm (28 wires per inch) mesh.

Where the flame arrester is not of a suitable proprietary type the openings in the arrester's body must be at least of the same area as the cross-sectional area of the vent line.

Flame arresters or gauze must be complete and free of damage or restrictions.

Notes – Flame arresters not recognised as proprietary must be supported by satisfactory documentation.

The hole in the top in the filler cap as provided by the original engine or fuel tank manufacturer, on tanks no more than 27 litres (6 gal) capacity, is compliant.

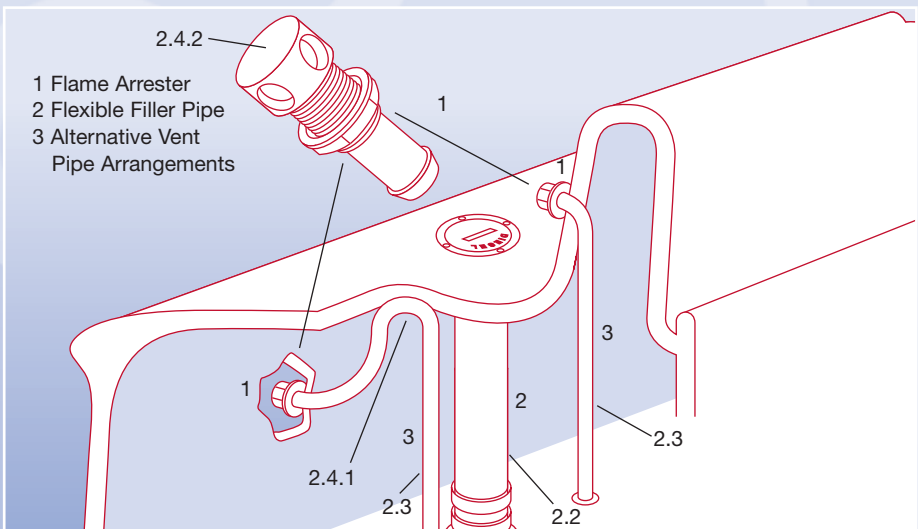

Diesel, paraffin or other fuel-oils escaping onto a source of ignition would create a fire hazard. There is even greater risk with petrol as the vent will exhaust highly flammable vapours regularly.

2.4.3/R REQUIREMENT

Is the fuel tank vent outlet in a position where no danger will be incurred from leaking fuel or escaping vapour?

Check the position of each vent outlet.

Vent outlets must be clear of any potential sources of ignition and must be in a position where no danger will be incurred from leaking fuel or escaping vapour into the interior of the vessel.

Notes – The hole in the top in the filler cap as provided by the original engine or fuel tank manufacturer, on tanks no more than 27 litres (6 gal) capacity is compliant.

Open vessels such as RIBs with no accommodation and having a continuous deck or sole, which is fuel tight to the interior of the vessel, including bilge spaces, meet this requirement.

Diesel vent outlets within self-draining cockpits having a continuous deck or sole that are fuel tight to the interior of the vessel, including bilge spaces, meet this requirement.

2.5 Fuel tanks - design and condition

This section considers the vulnerability of fuel tanks to leaks or failures that can lead to fuel and/or fuel vapour building up in the interior of the boat. It also covers the potential for chemical reaction between the fuel used and the tank material. The final concern is the fuel tank's fire resistance which can help prevent a major escalation of a small fire close to the tank.

Any stress in your boat's fuel tank, lines, or fittings, caused by movement in the system, could lead to a persistent or even catastrophic fuel leak.

2.5.1/R REQUIREMENT**Are the fuel tanks secure?**

At each fuel tank, check for signs that movement has occurred.

Assess the extent of possible movement by applying light manual force to each tank.

Fuel tanks must be free of signs of movement and incapable of movement under light manual force.

Note – Do not apply light manual force to fuel tanks that are too heavy to move.

Choosing the wrong material for a boat's tank, could introduce weakness and/or poor fire resistance. Unsuitable types of materials may be susceptible to corrosion and/or chemical reaction with the fuel inside. The wrong material may not be strong enough or may not have the right durability to prevent permeation or cracking. Failure could lead to fuel or fuel vapour building up unnoticed within the confines of your boat.

SUITABLE MATERIALS INCLUDE:

Diesel fuel	Petrol
Untreated mild steel	Aluminium alloy [†]
Mild steel*	Lead-coated steel
Aluminium alloy [†]	Brass
GRP/FRP	Copper (tin-coated internally)
Stainless steel	Internally galvanised mild-steel
Fire-resistant polyethylene tanks ^{††}	Stainless steel
	Fire-resistant polyethylene tanks ^{††}

*hot dip zinc-coated after fabrication

[†]containing not more than 0.1% copper

^{††}CE-marked and suitable for installing in craft using inland waterways.

AVOID THE FOLLOWING MATERIALS

Diesel fuel	Petrol
Lead-coated steel	Untreated mild steel
Copper	Interior painted tanks
	Internally galvanised steel
	GRP/FRP

2.5.2/R REQUIREMENT

Are fuel tanks made of suitable materials?

At each fuel tank check the material and check for evidence of obvious suitability.

Fuel tanks must not be manufactured with obviously unsuitable materials.

Materials **obviously** suitable for diesel include:

- aluminium alloy
- 'CE'-marked plastic
- GRP/FRP
- mild steel
- stainless steel.

Materials **obviously** suitable for petrol include:

- aluminium alloy
- brass
- 'CE' marked plastic
- stainless steel.

Notes – Examiners are not required to identify whether fuel tanks are lined or otherwise internally coated. A judgement will be made on suitability from a visual assessment of the tank's external surfaces.

If inaccessibility prevents a general assessment of the fuel tank material, it is 'not verifiable', and will be considered as non-compliant until the suitability of the material can be verified.

Where suitability cannot be verified and yet the material is not 'obviously unsuitable', the tank condition check (2.5.3) when accessible, will determine whether requirements are met and passed at 2.5.2 and 2.5.3. If the condition requirements at 2.5.3 are not met, the tank will fail at 2.5.2 and 2.5.3.

Even some of the best materials and jointing methods can deteriorate over time, due to corrosion, shocks and vibration.

2.5.3/R REQUIREMENT**Are fuel tanks, including seams and openings, in good condition and leak-free?**

Check the condition of all fuel tank surfaces, seams and openings which can be seen and reached.

Fuel tanks, including seams and openings, must be free of leaks, heavy corrosion, deep pitting or any other signs of material failure.

All inspection and cleaning access closing plates must be secured in place and leak-free.

Notes – If a tank's inaccessibility prevents a general assessment of its condition, it is 'not verifiable' and consequently considered as non-compliant until its general condition can be verified as acceptable. Particular attention should be paid to areas under dipsticks/sounding pipes for evidence of damage from dipstick 'bounce', where these are accessible.

Supplementary information on assessing deterioration of plastic tanks is available on www.boatsafetyscheme.com or by post or email from the BSS Office.

If there is a fire near the tank, it is crucial that the tank material does not fail immediately, causing an escalation. Soft-soldered joints could easily fail in a fire and for this reason are not permitted.

2.5.4/R REQUIREMENT**Are fuel tanks within engine spaces suitably fire resistant or otherwise protected against the effects of fire?**

Identify fuel tanks located within engine spaces.

If present, at each non-metallic fuel tank look for the manufacturer's plate for evidence of intrinsic fire resistance or verify this by examining any presented declaration from the manufacturer or supplier.

At each metallic fuel tank check for signs of soft-soldered seams where these can be seen or reached.

Non-metallic fuel tanks must have intrinsic fire resistance of at least 2½ minutes at 600°C (1112°F) or be otherwise protected from fire.

Metallic tanks must not have soft-soldered seams.

Note – Supplementary information on assessing plastic tanks is available on www.boatsafetyscheme.com or by post or email from the BSS Office.

Here we consider the hazard of radiated heat. Petrol tanks placed near an engine or heating appliance run the risk of generating flammable vapours and the potential for fire or explosion.

2.5.5/R REQUIREMENT

Are petrol tanks installed at the required distances from heat sources or protected by a heat baffle?

Measure the distance from any petrol tank to any engine, exhaust system or other heat source.

Check for the presence of a fire-resistant baffle between any such petrol tank and heat source.

Petrol tanks must be at least 100mm (4 in) from general heat sources and at least 250mm (10 in) from a dry exhaust.

If the distances are less than those prescribed a fire-resistant baffle in good condition must protect the tank from radiated heat.

2.6 Fuel gauges

An inappropriately installed gauge on your tank could introduce a serious weakness.

Glass or plastic fuel-sight tube gauges can easily be damaged by knocks or the heat from a fire, leading to a complete loss of the tank contents. With diesel or paraffin tanks, limiting any potential fuel escape is key to maintaining protection.

2.6.1/R REQUIREMENT

Are any glass or plastic tube or strip-type fuel gauges fitted to diesel tanks only?

Check each petrol tank for glass or plastic tube or strip-type fuel gauges.

Petrol tanks must not be fitted with glass or plastic tube or strip-type fuel gauges.

2.6.2/R REQUIREMENT

Are any glass or plastic tube or strip-type fuel gauges protected against damage and by self-closing valves?

Check each diesel or paraffin tank for the provision of glass or plastic tube or strip-type fuel gauges.

If provided check the installation arrangements.

Glass or plastic tube or strip-type fuel gauges must be:

- protected against physical damage; **and**,
- closely coupled (connected) to the tank; **and**,
- fitted with self-closing valves at top and bottom (note that the self-closing valve at the top is not required if the gauge connection is made to the top of the tank); **and**,
- complete and free of leaks and other signs of damage.

Note – Self-closing valves are not required for fuel gauges on any diesel fuelled vessel formerly used for the commercial carriage of freight or passengers or as a tug or as an icebreaker and which is to be licensed for use as a pleasure vessel, or registered for use as a houseboat, unless used for the purposes of hire or reward. Documentary evidence of former use addressed to the BSS manager is required to enjoy this exception.

Weak and poor condition gauges could fail and allow fuel to escape.

2.6.3/R REQUIREMENT

Are all fuel gauges and level-indicators in good condition and free of leaks?

Check any fuel tank fuel gauge and level-indicator for condition.

Fuel gauges and fuel level-indicators must be free of leaks, signs of damage or missing components and fixings, and must not have fuel behind any transparent cover or damage to any glass or other transparent cover.

Note – loose or damaged gauge needles, or other such level-indicators, mounted behind any glass or transparent cover do not constitute non-compliance.

The openings for dipsticks are potential weak points for introducing leaks and spills.

2.6.4/R REQUIREMENT

Are fuel tank gauge openings for dipsticks etc closed by a fuel-tight cap or fitting?

Check any fuel tank dipstick openings for a fuel-tight cap or fitting, and check for indications of fuel leaks.

Fuel tank openings used for dipsticks or sounding rods must be closed by a cap or fitting and must be leak-free.

2.7 Petrol fuel system electrical bonding

This section addresses the hazards related to static charges and petrol vapours. The build-up of static charge, from fuel flowing through the filling pipe could result in sparks, which in turn could ignite petrol vapour.

2.7.1/R REQUIREMENT

Are all metallic components in the petrol filling and tank system electrically bonded to earth?

Check all petrol filling and tank systems for the presence of electrical bonding.

Where petrol filling lines have non-conducting sections, an electrical bond between all metallic parts, e.g. tank, filling point and any intermediate hose connectors, must be fitted.

Where the deck and hull are non-conducting, or where the filling point is non-conducting, all metallic petrol tanks, and all metallic petrol filling components, must be electrically bonded to an earth point in direct electrical contact with the surrounding water.

Best practice

We recommend using cable of at least 2.5mm² for bonding.

b

2.7.2/R REQUIREMENT**Are all parts of electrical bonding systems in good condition?**

Check the condition of the electrical bonding connections and cables where they can be seen or reached.

The electrical bonding system must show:

- no movement at any of the connections;
- no signs of damage or deterioration, or corrosion, along the cables or at their connections.

Note – all necessary electrical bonding connections must be seen or reached in order to be able to establish the existence of adequate bonding provision.

Best practice

We recommend you also follow these bonding precautions with any diesel fuel systems on your boat.

b**2.8 Fuel tank connections**

Leaking fuel from a poor connection or an unsuitable pipe is a hazard. If there is a fire, the system must be resistant to the heat and flames.

It is known that fuel can leak past tank drains which are worn, or which have not been properly closed.

2.8.1/R REQUIREMENT**Is the fuel tank drain fitted with a plug or cap that can only be removed with tools?**

Check each fuel tank for the presence of a fuel drain facility.

If fitted, check the drain outlet for the presence of a plug, cap or blank.

If present, the outlets from fuel tank drains and drain valves must be terminated with a 'tools-to-remove' plug, cap or blank.

Note – The provision of a fuel tank drain facility is not a requirement.

2.8.2/R REQUIREMENT

Are the petrol feed and return (if fitted) line connections in lift-pump systems made to the top of the tank?

Check for the presence of a petrol fuel system with a lift-pump supply. If present, check all petrol feed and return (if fitted) line connections are made to the top of the tank.

Petrol feed lines and return lines must be connected to the top of the fuel tank on lift-pump feed systems.

Note – ‘Top of the tank’ means the top plate of the fuel tank or the highest part of the side of the tank.

2.8.3/R REQUIREMENT

Is the petrol feed line on a gravity system fitted with a cock or valve directly attached to the tank?

Check for the presence of a gravity-fed petrol installation and check for the presence of a cock or valve in the petrol feed line directly attached to the tank.

The petrol feed line on gravity-fed petrol installations must be protected by a cock or valve directly attached to the tank.

Note – A gravity-fed petrol installation is one where there is no lift-pump to move the fuel from the tank to the engine and the height of the tank is above that of the engine.

Best practice

We recommend that diesel fuel feed or return lines are drawn through the top of the tank, or as near to the top of the tank as is practical.

b

2.8.4/R REQUIREMENT**Are tank connections and tank valves accessible for inspection, in good condition and leak-free?**

Check the accessibility of tank connections and tank valves, and check condition by sight and touch.

Fuel tank connections and tank valves must be accessible for inspection, secure and free of leaks, signs of damage or deterioration.

Notes – If any tank connections or tank valves are inaccessible for inspection and the condition is ‘not verifiable’, they will be classified as non-compliant until their condition can be verified as acceptable.

This requirement applies to all tank connections and valves, including fuel filling lines, vent lines and balance pipes.

2.9 Fuel tank balance pipes

Balance pipes link fuel tanks and they are only permitted on diesel fuel tanks. The risk of allowing them in petrol installations, where failure could lead to a bilge containing volatile fuel, is too great.

2.9.1/R REQUIREMENT**Are multiple petrol tank systems free of balance pipes?**

Check for the presence of multi-petrol tank systems and check for the presence of balance pipes.

Petrol systems must not be fitted with balance pipes.

Best practice

If your boat has a balance pipe between its fuel tanks, we recommend strongly that you ensure it also has leak-proof and efficient valves directly attached to the tanks. If the balance pipe fails, these can be used to shut off the flow of fuel into the boat.

Flexible hose, including armoured hose, can be used as a balance pipe provided that the hose is suitable for the fuel in use and has the required minimum fire resistance (see 2.10.2). It is recommended that a valve is fitted at both ends.

b

Balance pipes will usually be filled with fuel unless the fuel tanks are empty. They are subject to the same risks from deterioration, unsuitability and of impact as the tanks they connect, where failure could allow large amounts of fuel to escape into the interior of the craft.

2.9.2/R REQUIREMENT

Are balance pipes on diesel tank systems made of suitable materials and are they in good condition and leak-free?

Check the material of all diesel balance pipes that can be seen and check for evidence of suitability.

Check the condition of each balance pipe and its connections where they can be seen or reached.

Diesel system balance pipes must be made of suitable materials, and must be free of leaks, signs of damage and/or deterioration.

Metallic materials suitable include:

- aluminium alloy
- copper
- mild steel
- stainless steel.

Non-metallic materials suitable include:

- GRP/FRP
- Hose in accordance with Checklist Item 2.10.2.

Notes – Where the suitability of the balance pipe material cannot be verified, and yet the material is not ‘obviously unsuitable’, its condition will determine whether the requirement has been met.

Balance pipe connections must comply with the requirements at 2.11 (Fuel line connections). If not compliant with all the requirements at 2.11 the pipe fails to comply with 2.9.2.

When fuel filler hose is connected to a balance pipe it must be checked in the same way as a hose permanently charged with fuel – see 2.10.

2.10 Fuel feed, return, and on-engine lines

Fixed pipes can over time become damaged and release fuel, owing to the effects of vibration and strain.

2.10.1/R REQUIREMENT

Are all rigid fuel feed and return lines made of suitable materials?

Check the material of all rigid fuel feed and return lines that can be seen and check for evidence of suitability.

Rigid fuel lines must be made of suitable materials.

Suitable materials include:

- aluminium alloy
- copper
- mild steel (for diesel only)
- stainless steel.

Note – Where its suitability cannot be verified and yet the material is not obviously unsuitable, the fuel line condition checks (2.10.3) will determine whether requirements are met and passed at 2.10.1 and 2.10.3. If the condition requirements at 2.10.3 are not met, the tank will fail at 2.10.1 and 2.10.3.

The useful life of flexible hose depends on many factors, including storage and operating conditions. It is likely that the hose may need to be changed several times during the lifetime of your boat. The risk of early failure through damage from heat and abrasion is the key factor.

2.10.2/R REQUIREMENT

Are all flexible fuel feed and return hoses suitable for the fuel used and fire resistant?

Check the marking on all fuel feed and return hoses.

Fuel feed and return hoses must be marked, to denote both suitability for the fuel used and fire resistance, to BS EN ISO 7840 or an equivalent standard.

Notes – Hoses marked to SAE J 1527 and DIN 4798 are acceptable.

Armoured or other external braiding is not evidence of hose suitability or fire resistance. Such hoses must be marked as above.

Where a hose is not marked as meeting an accepted standard but its suitability is claimed, evidence should be sent to the BSS Office for consideration of the claim.

Fuel hose suitability may be supported by a written declaration from the hose manufacturer or supplier or, if appropriate, from the engine manufacturer/supplier or mariniser.

Best practice

Flexible hose has a lower fire-resistance than metallic pipe and for all these reasons we highly recommend that you restrict the length of hose used in the fuel system to the absolute minimum, i.e. the minimum length necessary to cope with vibration or the movement of engines and boat structures.

b

Leaks from insecure and poor condition lines present a risk of fire and/or explosion.

2.10.3/R REQUIREMENT

Are all fuel feed and return lines secure and in good condition?

Check the condition of all fuel feed and return lines, which can be seen or reached.

Apply light manual force to check security of all rigid fuel lines that can be reached.

Fuel feed and return lines must be free of leaks, signs of damage or deterioration.

All fuel feed and return hoses must be free of leaks, flaws, brittleness, cracking, abrasion, kinking and 'soft spots'.

Rigid fuel feed and return lines must not move under light manual force.

Note – Pay particular attention to fuel lines etc close to hot exhausts and other sources of heat.

Failure can result if strain on the joints and the fabric of the hose caused by the weight of the hose and the fuel it carries is not prevented.

2.10.4/R REQUIREMENT

Are all flexible fuel feed and return hoses properly supported?

Check flexible fuel feed and return hoses where they can be seen or reached for support and protection.

Fuel feed and return hoses must be supported clear of anything likely to damage them, or be otherwise protected.

Note – Pay particular attention to sharp engine components, engine bearers and other vessel structures.

Some engines are unable to meet traditional marine standards of metallic pipes, or even newer standards such as the use of fire-resistant hose without modification to the injectors themselves. In order to accommodate these engines, and the original non-fire resistant plastic or rubber tubing, some alternatives are detailed below.

2.10.5/R REQUIREMENT

Do the injector leak-off (spill rail) arrangements meet specified requirements?

Check the arrangements for the injector leak-off (spill rail).

Injector leak-off (spill rail) arrangements must meet all the requirements for fuel feed and return pipes, flexible hose and connections; or,

- utilise the direct return to tank; or,
- return to the fuel system through a non-return valve.

Notes – Vintage and traditional engines designed to return the injector leak-off fuel to a metal catch pot are acceptable provided the metal catch pot is securely mounted and is free of leaks, signs of damage or deterioration.

Supplementary information on spill rail options is available on www.boatsafetyscheme.com or by post or email from the BSS Office.

Injector leak-off hoses fitted by the manufacturer within an enclosure on the engine meet this requirement.

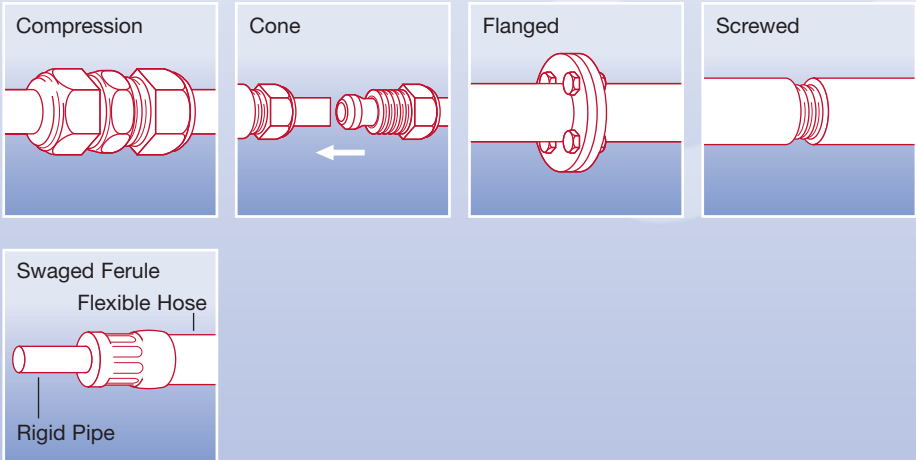

2.11 Connections

Some jointing methods are intrinsically weaker than internationally recognised standards. Soft-soldered and push-on joints may fail at any time, but especially in a fire, adding more fuel to the flames.

2.11.1/R REQUIREMENT

Are all fuel line connections of the correct type and leak-free?

Check the type of fuel line connections that can be seen or reached and check for leaks by sight and touch.

Fuel line connections must be screwed, compression, cone, brazed or flanged.

Flexible fuel hose connections must either be pre-made end fittings on hose assemblies, or hose clips/clamps onto hose nozzles or formed pipe-ends.

Fuel line connections must be free of leaks, signs of damage or deterioration.

Notes – Soft-soldered joints are not acceptable. Where there is concern that joints may be made with soft solder, the owner must provide evidence that this is not the case and that the joints meet the requirements.

Injector leak-off (spill rail) arrangements having push-on connections on flexible fuel lines are acceptable for options covered by the bullet points at Checklist Item 2.10.5.

An insecure component is a sign of a potential weakness that could allow a fuel escape.

2.11.2/R REQUIREMENT

Are all fuel line connections, cocks, valves, fittings and other components secure?

Apply light manual force to check security of all fuel line connections, cocks, valves, fittings and other components that can be reached.

Fuel line connections, cocks, valves, fittings and other components must not move under light manual force.

Checks have found that the use of ineffective clamps and connections have caused leaks.

2.11.3/R REQUIREMENT

Are flexible fuel hose connections made with hose clips or clamps effective and in good condition?

Check flexible fuel hose connections made with hose clips or clamps that can be seen and reached. Assess their condition and look and feel for leaks.

Pull using light manual force to check security of all hose connections.

Flexible fuel hose connections made with hose clips or clamps must:

- be suitably sized, that is, not so oversized that the band forms an elliptical shape or so undersized that no tightness is achieved; **and**,
- be appropriately tight, that is, not so loose that the connection can be pulled forward or back under light manual force, nor so tight that the hose is excessively pinched; **and**,
- show no signs of damage or deterioration at the clip or clamp; **and**,
- show no signs of damage or deterioration at the hose caused by the clips or clamps.

Note – Do not apply the light manual force check to injector leak-off (spill rail) arrangements having push-on connections. Supplementary information on spill rail options is available on www.boatsafety.com or by post or email from the BSS Office.

2.12 Fuel filters

Non-marine fuel filters can be vulnerable to damage from fire and impact damage as well as, the vibration, shock, corrosion and movement found in marine use. The failure of a fuel filter could lead to a very significant leakage of fuel, which if the cause was a fire, could add fuel to the flames.

2.12.1/R REQUIREMENT**Are fuel filters in good condition?**

Check the condition of all fuel filters.

Fuel filters must be free of leaks and signs of damage or deterioration to any part of the filter assembly.

Note – The requirements at section 2.12 must be applied to all forms of fuel filters, including water traps, sedimenters, agglomeraters, etc.

The failure of a fuel filter or its plug can lead to additional fuel being added to any fire.

2.12.2/R REQUIREMENT**Are all fuel filters of a suitable proprietary marine type?**

Check that all fuel filters are marked or recognised as suitable proprietary marine filters. If not marked or recognised as suitable, verify this by examining any presented declaration from the manufacturer or supplier.

Fuel filters must be of a suitable proprietary marine type.

2.12.3/R REQUIREMENT**Are all fuel filters inside engine spaces fire resistant?**

Check all fuel filters (including drain plugs) located inside engine spaces are marked or recognised as fire resistant. If not marked or recognised as being suitably fire resistant, verify this by examining any presented declaration from the manufacturer or supplier.

Fuel filters (including drain plugs) located inside engine spaces must have intrinsic fire resistance of at least 2½ minutes at 600°C (1112°F).

Note – All-metal fuel filters are considered ‘sufficiently fire resistant’. Fuel filters marked with ISO 10088 are acceptable.

2.13 Fuel shut-offs

It is important to ensure the fuel system can be prevented from feeding fuel to a small incident and making it a serious one.

2.13.1/R REQUIREMENT

Is an emergency fuel shut-off installed in every fuel feed line?

Check the means to shut off the fuel in the fuel feed line from every fuel tank.

An effective emergency shut-off must be installed in all fuel feed lines. Any of the following methods are acceptable:

- a manual shut-off valve or cock; or,
- all fuel lines, including those on the engine, being above the level of the top of the tank; or,
- an anti-siphon valve at the tank, providing it was installed by the boatbuilder; or,
- an electrically operated valve at the tank, activated to open only during engine starting or running, provided that a manual emergency operating or bypassing device is present.

Note – Claims that an emergency shut-off facility is provided by an anti-siphon valve or an electrically operated valve, need to be verified with the help of the BSS Office.

An emergency fuel shut-off needs to be easy to reach and operate without undoing any panels, etc as soon as it is needed.

2.13.2/R REQUIREMENT

Are all fuel shut-off valves or cocks, or their means of operation, in a readily accessible position?

Check for the presence of fuel shut-off valves or cocks. If present, check their accessibility or the accessibility of their means of operation.

Fuel shut-off valves or cocks, or their means of operation, must be installed in a readily accessible position.

Best practice

We strongly recommend that you have some way of operating this valve or cock from outside your boat's engine compartment.

b

Information

When choosing a solenoid-controlled shut-off valve, seek the supplier's assurance as to its suitability for the fuel in use.



New crewmembers, visitors or even fire-fighters who need to shut down the fuel supply in an emergency must be able to identify the position of the shut-off valve quickly.

2.13.3/R REQUIREMENT

Are all fuel shut-off valves or cocks, or their means of operation, in open view or their location clearly marked?

Check for the presence of fuel shut-off valves or cocks.

If present, check that fuel shut-off valves or cocks, or their means of operation, are in open view with all removable lids, deck boards, curtains, doors, etc in place.

If not in open view check their location is clearly marked in open view.

Fuel shut-off valves or cocks, or the means to operate them, must

- be in open view with all removable lids, deck boards, curtains, doors, etc in place; or,
- have their location clearly marked in open view.

Gravity-fed petrol systems present greater risks than others and merit special measures. The speed with which petrol can ignite means that you may not have time to move away from the helm and if you did it could put you in greater danger.

2.13.4/R REQUIREMENT

Are petrol gravity-fed fuel lines provided with the required fuel shut-off facilities.

Check for the presence of a gravity-fed petrol installation.

If present, check that a second shut-off valve or cock, or a means of operating the main valve or cock, can be reached from the steering position and check its accessibility.

Gravity-fed petrol installations must have a second cock, or a means of operating the main cock, in a readily accessible position within approximately 2m (6 ft 6 in) of the steering position.

2.14 Carburettors

Petrol can overflow into the engine space as a result of a flooded carburettor. Down-draught carburettors generally overflow 'safely' i.e. any petrol is contained within the inlet to the engine and cannot escape outside. However, side- and up-draught types can overflow outside the carburettor body and this would be a significant hazard as there is a danger of petrol leaking onto a hot engine or exhaust and potentially starting a fire or causing an explosion.

2.14.1/R REQUIREMENT

Are all non-down draught carburettors fitted with a drip tray?

Check for the presence of a non-down draught type carburettor.

If present, check that a drip tray is fitted.

Non-down draught carburettors must be provided with a drip tray.

Note – Certain down-draught carburettors are capable of overflowing. If you believe you may have an overflowing type you can contact the BSS Office for verification.

Down-draught

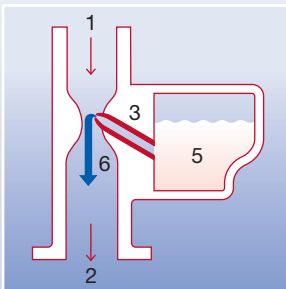

1 Air intake
2 Fuel/Air mixture to Engine

Side-draught

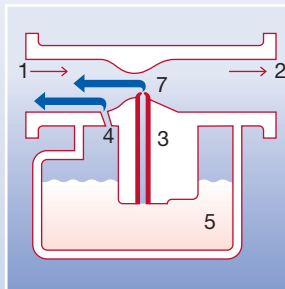

3 Main Jet
4 Vent

Up-draught

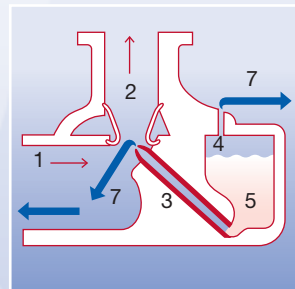

5 Fuel Bowl
6 Overflow
7 Overflow Possible

2.14.2/R REQUIREMENT

Is the carburettor drip tray in good condition, leak-free, and easily emptied?

Check the condition of any carburettor drip tray.

Check that it is removable or fitted with an emptying cock.

Carburettor drip trays must be removable or fitted with an emptying cock, and must be free of leaks, signs of damage or deterioration.

Without protection fixed to the drip tray, flames produced as a result of an engine backfire could ignite any spilt fuel.

2.14.3/R REQUIREMENT

Is the carburettor drip tray fitted with effective flame-arresting gauze permanently attached along all edges?

Check the carburettor drip tray gauze for effectiveness by comparing it with a sample of gauze of the correct mesh.

Check the condition of the gauze and the method of attachment to the tray.

Carburettor drip tray gauze must have a mesh of at least 11 wires per linear cm (28 wires per inch).

Gauze must be complete and free of restrictions, damage, and must be permanently and continuously attached to the tray along all edges.

2.14.4/R REQUIREMENT

Is a petrol, petroil or paraffin engine fitted with flame trap or air filter?

Identify the air intake of petrol, petroil and paraffin engines and look for the presence of a flame trap or air filter.

Petrol, petroil and paraffin engines must have a flame trap or air filter fitted to the air intake.

Note – The BSS examination does not include for dismantling the air filter to determine the nature of the filter element, if any.

2.15 Engine installation

Undue movement of the engine may place a strain on the fuel system and lead to fuel escapes.

Information - Oil-tight tray

Pollution prevention is a requirement. Please read Chapter 9 for the requirements in regard to anti-pollution protection including the need for an oil-tight tray or similar oil discharge measures.



2.15.1/R REQUIREMENT

Are all parts of the engine mounting systems secure and in good condition?

Check engine mounting systems for condition and completeness where they can be seen or reached.

Engine mounting systems must:

- show no signs of fractured engine mounting brackets; **and**,
- not have loose, missing or fractured bolts or nuts; **and**,
- show no evidence of significant deterioration of any flexible mounts; **and**,
- show no signs of damaged or heavily corroded metal bearers or rotten timber bearers.

2.15.2/R REQUIREMENT

Are exhaust system components effectively cooled, lagged or shielded?

Identify the presence of 'dry' exhaust systems, or parts of 'wet' exhaust systems not cooled by water, and check for the presence of lagging or shielding.

Check the condition of lagging and check the surrounding structures or components for signs of heat damage.

'Dry' exhaust systems, or those parts of 'wet' exhaust systems between the manifold and the water injection elbow, must be effectively lagged or shielded.

Lagging must be free of signs of damage or deterioration, and must not be loosely fitted.

Lagging or shielding must provide complete coverage.

Notes – Signs of heat damage on structures or components adjacent to exhaust systems may indicate that the exhaust lagging or shielding is not effective.

All parts of 'dry' exhaust systems must be lagged or shielded including silencers, silencer ends and system joints/connections, except for manifolds and flexible exhaust pipe sections which do not.

2.16 Steam-powered engines

2.16.1/R REQUIREMENT

Is the steam engine pressure system supported by an inspection certificate issued by a competent person?

Read carefully the steam engine pressure-system inspection certificate. Check the validity of the certificate and check the terminology indicates the pressure system is in a satisfactory condition.

Steam engine pressure systems must be supported by an inspection certificate. Pressure-system inspection certificates must:

- relate to the vessel being examined;
- be completed by a competent person;
- indicate satisfactory condition;
- must be less than 14 months old or within any 'run-out' date.

Note – Guidance on the assessment of pressure-system inspection certificates is available on www.boatsafetyscheme.com or by post or email from the BSS Office.

2.16.2/R REQUIREMENT

Is the steam engine boiler fuel supply system compliant with the applicable BSS requirements?

Identify the type of fuel to the steam engine boiler.

Apply the relevant Part of the BSS requirements to the fuel supply system.

Steam engine boiler fuel supply systems must be compliant with the applicable BSS requirements.

Best practice

To minimise the risk of a potential pressure system explosion, a steam-powered engine needs to have regular checks and comply with industry practice.

For your own protection, it is recommended that the pressure system is covered for third-party risks by a current insurance policy.

b

2.17 LPG-propelled vessels

The incorrect installation of fuel supply arrangements to LPG-fuelled propulsion engines may lead to an explosion of LPG exploding and fire. On dual fuel petrol/LPG installations, there is a risk of damaging carburettor components, which could cause a petrol vapour explosion.

2.17.1/R REQUIREMENT

Do the fuel supply arrangements to LPG-fuelled propulsion engines comply with LPGA CoP 18 and are any dual-fuel petrol/LPG arrangements of an acceptable type?

[LPG-fuelled propulsion engines can only be checked for compliance by prior arrangement by the owner with the BSS Office.]

Check the fuel supply type to propulsion engines and identify those fuelled by LPG or dual-fuel petrol/LPG.

The fuel supply arrangements to LPG-fuelled propulsion engines must comply with LPGA Code of Practice (CoP) 18.

Any dual-fuel arrangements must be installed and maintained in accordance with the engine manufacturer's guidelines for marine applications.

Notes – Where a propulsion engine is fuelled by LPG, please contact the BSS Office who can arrange for an examiner competent to apply LPGA CoP 18 to undertake a full examination of the vessel.

Steam-propelled vessels having boilers fuelled by LPG are not covered by this check.

Examiners may determine compliance of portable LPG-fuelled generators to applicable BSS requirements.

3

Electrical installations

The Boat Safety Scheme Essential Guide



For more technical information

The requirements in this chapter have been informed by, and may refer to, the following technical references, codes and regulations. If you are building, fitting-out or making substantial changes to a vessel, we strongly recommend you refer to, and take account of, the codes and standards below:

- **BS 4343:1968 'Specification for industrial plugs, socket-outlets and couplers for a.c. and d.c. supplies' (superseded, withdrawn)**
- **BS EN ISO 10133:2001 'Small craft. Electrical systems. Extra-low-voltage d.c. installations'**
- **BS EN ISO 13297:2001 'Small craft. Electrical systems. Alternating current installations'**
- **BS EN 60309-1:1999 'Plugs, socket-outlets and couplers for industrial purposes. General requirements'**
- **IP67 an immersion protection standard for circuits subject to intermittent immersion. Details in BS EN 60529:1992 'Degrees of protection provided by enclosures (IP code)'**
- **British Marine Electronics Association (BMEA) 'Code of Practice for Electrical & Electronic Installations in Small Craft' is available from British Marine Federation Technical Department: tel: 01784 223634 or email: technical@britishmarine.co.uk**



BSS Essential Guide

Faulty, or poorly installed electrical systems are a hazard and could place you and others at risk. This chapter covers the need to minimise the risks from short circuits and overheating cables, both of which are a common cause of boat fires. It also addresses the potential risks linked to hydrogen, a highly flammable gas that is a by-product of charging your batteries, which is easily ignited by low energy sparks.

You can reduce these risks by making sure that batteries are stowed in a ventilated area, that batteries and cables cannot move around, that your fuses and circuit-breakers are correctly installed and rated for the circuits they protect and that wear and tear has not left your system vulnerable to failure.

Best industry practices and competent installation reduces the risk of personal injury caused by electric shocks. Further information on present industry practice is available through the British Marine Electronics Association's Code of Practice or from the small craft electrical standards (see technical information section on previous page).

Boats obliged to meet BSS electrical requirements must comply with the following:

- 8** All electrical systems must be designed, installed and maintained in a way that minimises the risks of explosion or of fire starting and spreading.

- 9** All electrical systems must be capable of being safely and quickly disconnected from their power source(s) in an emergency.

- 10** Control and emergency devices, or their means of operation, must be marked when not in clear view or when their function is not clear.

- 11** All battery compartments containing unsealed or open-vented batteries must be adequately ventilated to prevent a build-up of a flammable mix of gases.

3.1 Battery storage

Most batteries produce hydrogen gas when being charged. If this gas builds up, it can be easily ignited and explode.

3.1.1/R REQUIREMENT

Are all unsealed or open-vented batteries ventilated to prevent risk of explosion through hydrogen accumulation?

Identify the location of all batteries.

If batteries are stored within an engine, accommodation or other non-dedicated battery space, check that the space is ventilated.

If batteries are stored within a dedicated battery space or box:

- check if the space or box has any ventilation; **and**,
- check the height of the ventilation provision and the route of any ducted ventilation.

Check the ventilation pathway from all battery storage locations leads to the outside of the hull or superstructure.

All unsealed or open-vented batteries must be stored within a ventilated space.

Dedicated battery spaces or boxes for unsealed or open-vented batteries must be ventilated at the top or the highest point of the sides of the space or box and any ductwork used must run horizontally or upwards.

The ventilation pathway from all battery storage locations must lead to the outside of the hull or superstructure.

Notes – Battery manufacturer's recommendations must support storage in unventilated spaces where 'sealed'-type batteries are stored in a **non-ventilated space**. You must have documentation from the manufacturer indicating compliance, available for inspection.

Ventilation pathways into accommodation spaces having fixed high-level ventilation or into canopied areas are acceptable.

Battery covers must not allow the accumulation of hydrogen gas.

Where there is no ventilation provision, further information is available on www.boatsafety.com or by post or email from the BSS Office.

If batteries are able to move around there is potential for damage to the cables and for them to short-circuit, which could lead to fire. There is also a potential for the connections to short against the superstructure or sparks to be created by metal objects such as tools coming into contact with the terminals. If a battery can tip over, in addition to these hazards, the boat may also suffer from the effects of any acid spill leaking from the filling/ventilation points or from a cracked or damaged case.

3.1.2/R REQUIREMENT

Are batteries secure against excessive movement in any direction?

Check the extent all batteries and battery boxes can move.

Apply light manual force to verify the extent of movement.

All batteries must be incapable of movement in excess of 10 mm ($\frac{3}{8}$ in) any direction.

Note – restraint against vertical movement is generally required. However, batteries may be secured by means of a cradle or framework sufficient to ensure batteries remain secure under any condition up to 45° to the horizontal. Recesses, cradles or frameworks extending to half the height of the battery meet this allowance.

Best practice

If any batteries are connected to an alternator, or alternative battery-charging source, having a maximum charge rate in excess of 2kW (approx. 150 A at 13.8 V) it is strongly recommended to install a fan-assisted ducted ventilation system. The fan motor is best placed externally to the duct and battery space to avoid any potential for spark ignition. The fan should operate automatically during charging and the safe operation of the facility should be checked by a competent person on a routine basis.

b

- 1 Rubber Terminal Cover
- 2 Boxing

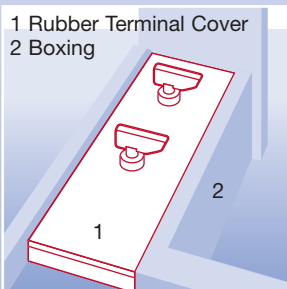

- 3 Battery Clamp Restraint
- 4 Wooden Cover

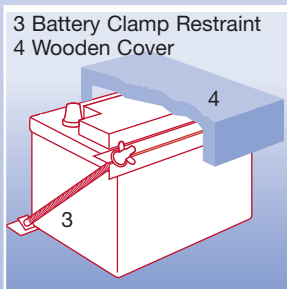

- 5 Strap Restraint
- 6 Battery Box Cover

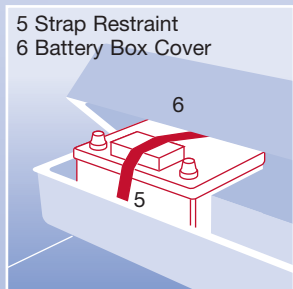

3.1.3/R REQUIREMENT**Are battery terminals correctly insulated or protected?**

Check for the presence of a battery cover or terminal covers.

Check material and condition of any battery cover or terminal covers.

All metal parts of battery terminals or connections must be insulated or protected by battery covers or terminal covers.

All battery covers or terminal covers:

- must be made of insulating material; **and**,
- must not allow any metal part of the terminal or connection to be exposed; **and**,
- must be free of signs of damage.

Note – deck boards, locker lids, etc made from or lined with insulating material may only be considered as battery covers where they will not be removed for any purpose other than gaining access to the batteries.

Best practice

Because of the potential risk of a gas explosion under fault conditions, we recommend locating batteries outside of accommodation areas or in sealed boxes ventilated directly to the outside. Batteries are best located away from heat sources.

b**3.1.4/R REQUIREMENT****Are batteries installed away from metallic petrol and LPG system components?**

Measure the distance between batteries not in a box and any metallic petrol or LPG system components installed directly above them.

Where batteries are installed within 300 mm (12 in) directly under metallic petrol or LPG system components, check the components for the presence of a conduit, shield or enclosure made of insulating material.

All batteries must be at least 300 mm (12 in) away from all metallic petrol and LPG system components installed directly above them, or the components must be contained within a conduit, shield or enclosure made of insulating material.

Note – all metallic petrol and LPG system components are covered by this check including tanks, cylinders, pipes, valves, filters, connectors, etc.

3.2 Cable specifications and condition

Exposed wiring could allow short-circuits, sparks and thus potentially cause fires. Exposed 230/240 V wiring can also give people on your boat an electric shock.

3.2.1/R REQUIREMENT

Are all electrical cables insulated?

Check all electrical cables which can be seen for the presence of outer insulation.

All electrical cables must be insulated.

Note – this check applies to both a.c. and d.c. cables.

Cables can overheat if they are not adequately sized or rated to carry the current required by the installation. Battery cables are subject to high currents, so it is crucial for the prevention of fire that these are suitable for their purpose.

3.2.2/R REQUIREMENT

Are battery cables of a sufficient current-carrying capacity?

Check the size of the following cables.

- battery to master switch;
- battery or master switch to starter solenoid;
- battery to battery;
- engine return to battery or master switch;
- battery to bow-thruster motor;
- battery to anchor winch motor;
- battery to inverter system (over 1000w size).

The battery cables prescribed in the check must be approximately 25mm².

Notes – Outboard engines having the engine manufacturer's original loom are not required to meet these dimensions.

The actual layout of cable runs may vary depending whether master switches are installed in the positive or the negative cables.

Best practice

The above are minimum recommendations. Systems may call for larger cable sizes, depending upon the loads encountered. To minimise this risk, ask advice of a suitably competent person whether your boat's wiring is of the right construction and grade and capable of carrying the required current safely.

b**Best practice**

We highly recommend that new electrical installations be made with multi-stranded conductors as single solid-wire cables are vulnerable to breakage where there is high vibration or repeated flexing.

b

Cables showing signs of damage or deterioration indicate that shorting or sparking is possible. Indeed, it may indicate that the cable or insulation is already subject to high temperature or even close to fire.

3.2.3/R REQUIREMENT**Are all cables free of damage or deterioration?**

Check the condition of all cables, which can be seen.

Check the condition of insulation and sheathing that can be seen.

All cables must be free of:

- signs of overheating; **and**,
- signs of damage or deterioration, such as broken cable strands, chafing, or heat damage.

Insulation and sheathing must show no signs of damage or deterioration caused by a reaction with water or fuel.

Note – This check applies to both a.c. and d.c cables.

Best practice

We recommend checking the condition of all of your boat's wiring during routine maintenance and inspection, to provide an assurance that all wiring including the cables, conduits, cable trays and connections remain effective and free of damage or deterioration.

b

3.3 Cable location

This may cause the hazard of shorting or sparking which can then lead to fire or explosion.

3.3.1/R REQUIREMENT

Are all electrical cables supported in a safe position?

Check the run of all cables which can be seen and identify any structure or item of equipment likely to cause impact or abrasion damage.

Identify any cables subject to the possibility of impact or abrasion damage and check for means of protection or support.

Check arrangements where cables can be seen passing through bulkheads or structural members.

Check the condition of all cable conduit or trays that can be seen.

All electrical cables must be:

- supported away from equipment likely to cause impact or abrasion damage; or,
- contained in a conduit or cable tray supported away from it.

Cables passing through bulkheads or structural members must be protected against chafing damage by the use of grommets, sleeves or sealant used effectively.

Cable conduit or cable trays must be free of signs of overheating or damage.

Notes – This check applies to both a.c. and d.c. cables.

For cables verified as double-insulated cables, where such cables pass through bulkheads and other structural members, the outer insulation (sheathing) should be considered as adequate protection, providing the insulation is in good condition.

Information

Bilge water level can usually be determined by the presence of a 'tidemark', the position of the bilge pump or its inlet, or the level at which the float switch is set.



There is a risk of sparks from damaged cables igniting fuels carried in adjacent fuel and gas pipes.

3.3.2/R REQUIREMENT

Are all cables clear of LPG and fuel supply lines?

Check the clearance of all electrical cables that can be seen from LPG or fuel supply lines.

Check any conduit is of a non-conducting material.

Electrical cables must be installed clear of LPG and fuel supply lines unless they are in a conduit made of non-conducting material.

Notes – This check applies to both a.c. and d.c. cables.

Cables verified as double-insulated (sheathed) cables are not subject to this check.

There is a risk of bilge water causing low-lying cable connections to short leading to a risk of overheating and fire.

3.3.3/R REQUIREMENT

Are all electrical cable connections above bilge water level or suitably protected?

Check the position of all cable connections that can be seen.

Where cable connections are below bilge water level, check for the presence of watertight enclosures marked as compliant with IP 67.

All electrical cables connections either must be above bilge water level, or, protected by a watertight enclosure meeting the IP 67 standard.

Notes – This check applies to both a.c. and d.c. cables.

The final cable connections to submersible bilge pumps, transducers or any other equipment intended for operation below bilge water are presumed to comply.

3.3.4/R REQUIREMENT

Are spark plug leads free of damage or deterioration and properly supported?

Check the support and condition of spark plug leads.

Spark plug leads must be:

- free of signs of damage or deterioration; **and**,
- properly supported away from the engine block or cylinder head.

Best practice

To keep cables in sound condition, we recommend keeping cable runs away from potential sources of heat or impact damage e.g. close to flues, where it could be kicked, etc. More guidance is available in ISO 10133 [DC] or ISO 13297 [AC].

b

3.4 Cable connections

Loose or ineffective cable connections can lead to sparking or increased resistance and overheating of the cable. As a result, the risk of fire or explosion is increased.

3.4.1/R REQUIREMENT

Are all battery cable connections effective and in good condition?

Check the type and condition of connectors to the cables listed at Checklist Item 3.2.2.

All battery cables listed at Checklist Item 3.2.2 must be fitted with soldered or crimped lug connectors or other pre-made connections of suitable proprietary manufacture.

All battery cable connections on cables listed at Checklist Item 3.2.2 must be free of:

- missing components or loose or poorly made connections; **and**,
- signs of damage or deterioration;
- excessively exposed or damaged cable strands.

Note – Battery terminals fitted with screw clamps are acceptable if the cable strands are protected by the use of spreader plates or tinned cable ends in the terminal.

3.4.2/R REQUIREMENT**Are all electrical circuit cable connections effective and in good condition?**

Check the type and condition of all electrical circuit cable connections that can be seen.

All electrical circuit cable connections must be free of:

- missing components or loose or poorly made connections e.g. applying compression crimp terminals without using the appropriate tool; **and**,
- signs of damage or deterioration; **and**,
- excessively exposed and/or damaged cable strands.

Note – this check applies to both a.c. and d.c. cables.

For your own safety, we strongly urge you to check that the correct arrangements for shore-to-boat connections are used.

3.4.3/A ADVICE**Are shore power and battery charging lead connections splash-proof to BS EN 60309?**

Check the type of shore power or battery charging appliance inlet connections fitted in any location likely to be subject to the weather or splashing.

Check the markings on the appliance inlet connection.

Shore power and battery charging lead connections that are exposed to weather or splashing, are recommended to be of a weatherproof type to BS EN 60309 Part 2 or equivalent.

Notes – If the appliance inlet connection for shore power or a battery charging lead is the ‘female type’, then the plug on the connecting lead will have exposed pins, see best practice box and photograph in Ch4 Pg6. There is a risk of electrocution from the exposed pins on the lead. An examiner or navigation officer finding such an arrangement may issue a BSS Warning Notice.

Existing connections marked to BS 4343 are equally as acceptable.

Best practice

We would like to draw your attention to the best practice information regarding sockets for shore supply on page 6 of Chapter 4.



3.5 Fuses and circuit-breakers

To be effective, the fuse or circuit-breaker must have a rating that is lower than the current that would cause damage to the circuit.

The safe operation of these devices must not be compromised.

3.5.1/R REQUIREMENT

Are fuses and circuit-breakers appropriately rated, complete and in good condition?

Check the rating, completeness and condition of all miniature circuit-breakers and fuses which can be seen.

Fuses and circuit-breakers must be:

- rated not greater than the rating specified on the fuse holder or the body of the circuit-breaker; **and**,
- rated less than the current-carrying capacity of the cable protected; **and**
- complete and free of signs of heat damage or deterioration; **and**,
- fitted securely.

Fuse holders must contain appropriate 'fuse wire' and not nails, silver paper, etc.

Circuit-breakers must not be held closed by the use of tape or other devices.

Notes – This check applies to both a.c. and d.c. systems.

The lack of a fuse or circuit-breaker is not a fail point.

Important information

When booking the boat's BSS examination, it is crucial that in making the arrangements with the examiner, you inform him or her of the exact locations of fuses, distribution boards and circuit-breakers, as necessary.



There is a potential risk of fire because of a reduced current carrying capacity or shorting if any fuse panels, boxes or holders in poor condition or are incomplete.

3.5.2/R REQUIREMENT

Are all fuse panels, boxes and holders and distribution boxes complete and in good condition?

Check all fuse panels; boxes and holders; and distribution boxes that can be seen for the presence of lids or covers covering exposed terminals, when designed to have one.

Check the condition of all fuse panels; boxes and holders; and distribution boxes that can be seen.

All fuse panels, boxes and holders and distribution boxes designed to have a cover must:

- have lids or covers covering exposed terminals; **and**,
- be free of signs of damage or deterioration.

Note – This check applies to both a.c. and d.c. supplies.

Best practice

If your boat has a 230/240V supply, we strongly recommend having a residual current device (RCD) to disconnect the supply automatically in the event of a fault, which may help protect someone from an electric shock.

b

3.6 Battery isolators

It is important that all power to the electrical system can be cut off in the event of an electrical fault or when leaving the boat, as well as when carrying out maintenance works.

Damage, overheating and fire may result if isolation switches cannot carry the maximum current, especially the engine starter motor circuit.

3.6.1/R REQUIREMENT

Are battery isolators fitted and are they as close as practicable to the battery?

Check for the presence of a battery isolator at each battery or bank of batteries.

Check the distance of battery isolators from batteries.

Battery isolators must be fitted to each battery or bank of batteries.

Battery isolators must be located as close as practicable to the batteries.

Notes – Accessibility takes precedence over proximity to the batteries.

If there are separate circuits connected to separate batteries, each of them must have a battery isolation switch. A combined-switch can be used, for example in a two-battery system, where one battery is used for starting the boat's engine and the other is used for domestic services.

Best practice

We recommend that battery isolators or their means of operation are located in an 'easy to reach location', where they can be quickly operated in the event of an emergency.

b

Certain circuits supplying power to equipment that requires a continuous supply, e.g. bilge pump, may bypass the battery isolation switch. However, the risks associated with a short circuit or overload fault must be minimised particularly when the boat is left unattended.

3.6.2/R REQUIREMENT

Do all electrical circuits pass through a battery isolator, or are those requiring a continuous supply otherwise protected?

Identify any electrical circuits bypassing the battery isolator.

Check that any electrical circuits bypassing the battery isolator supply the following equipment:

- automatic bilge pumps;
- security alarms (including marine radios);
- fire pumps;
- electronic navigation equipment with memories;
- any other equipment where the manufacturer's instructions indicate or specifically require direct connection to a battery, such as diesel-fired central heating boilers;
- battery charger outputs;
- inverters or combination inverter/chargers.

Check electrical circuits supplying any equipment on the specified list and which bypass a battery isolator, for the presence of a fuse or circuit-breaker, where the circuit can be seen.

All electrical circuits must pass through a battery isolator, except those that feed equipment requiring a continuous supply, which must be protected by a suitable fuse or circuit-breaker.

Notes – In cases where circuits directly connected to the battery do not appear in the specified list, compliance must be verified on request by supportive paperwork from the manufacturer or supplier.

The fuse or circuit-breaker protecting specified equipment bypassing a battery isolator must be installed where the circuit can be seen at examination or otherwise required. If not, it will be considered as not meeting the requirement, because the fuse or circuit-breaker is very unlikely to be located either where the circuit is hidden or be more than a short distance from the battery.

In the event of an emergency, shutting down electrical circuits may help prevent a fire starting or spreading. The ability to do so quickly can be vital.

3.6.3/R REQUIREMENT

Are battery isolators, or the means to operate them, in readily accessible positions?

Check the accessibility of battery isolators, or the means to operate them.

Battery isolators, or their means of operation, must be installed in readily accessible positions.

Any battery isolation switches or connections not in good working order or in poor condition may lead to overheating and fire if the current-carrying capacity is reduced.

3.6.4/R REQUIREMENT

Are battery isolators and connections complete and in good condition?

Check the completeness and condition of all battery isolators and connections.

Battery isolators and connections must be:

- free of missing fixings; **and**,
- free from signs of heat damage indicating an inability to carry the maximum current of the circuit; **and**,
- free from other signs of damage or deterioration.

In the event of an emergency, shutting down electrical circuits may help prevent a fire starting or spreading. The ability for anyone aboard the vessel to locate the isolator switch or means to operate it and do this quickly can be vital.

3.6.5/R REQUIREMENT

Is the location of all battery isolators, or the means to operate them, in open view, or their location clearly marked?

Check that all battery isolators, or their means of operation, are in open view with all removable lids, deck boards, curtains, doors, etc in place.

If not in open view, check their location is clearly marked in open view.

Battery isolators, or the means to operate them, must:

- be in open view with all removable lids, deck boards, doors, etc in place; or,
- have their location clearly marked in open view.

Best Practice

We recommend labelling the battery isolators to indicate the circuits they protect for example, 'STARTER' and 'SERVICES'.

b

3.7 Two-wire systems

For reasons of personal safety, we recommend that no part of the hull of the boat is used as part of the return circuit because of the risk of personal injury. A further disadvantage is that hull corrosion may be advanced as a result of electrolytic action.

3.7.1/A ADVICE

Is the electrical system insulated from the hull?

Check any wiring that can be seen to a suitable device such as a horn, headlamp, or navigation light for the presence of a two-wire insulated cable.

It is not recommended to use the hull as a conductor in an electrical system.

Note – An electrical fitting attached to a metal hull or superstructure and having only a single wire connected indicates the use of the hull as a conductor.

Unsuitable return cables in single wire installations may not be able to carry the starter current leading to possible overheating, damage and fire.

3.7.2/R REQUIREMENT

Is a low-resistance return cable provided from the engine or starter motor to the battery?

Identify the low-resistance return cable from the engine or starter motor to the battery (or battery master switch in systems having negative switching).

Apply the cable sizing checks at 3.2.2.

A low-resistance return cable from the engine or starter motor to the battery must be provided on all installations.

4

Electrically propelled vessels

The Boat Safety Scheme Essential Guide



For more technical information

The requirements in this chapter have been informed by, and may refer to, the following technical references, codes and regulations. If you are building, fitting-out or making substantial changes to a vessel, we strongly recommend you refer to, and take account of, the codes and standards below:

BS EN 60309-1:1999 'Plugs, socket-outlets and couplers for industrial purposes' – 'Part 2: Dimensional interchangeability requirements for pin and contact-tube accessories'



Electrically propelled vessels

The particular risks related to electric boats are mainly due to the presence of large banks of batteries and associated charging equipment. Hydrogen, a highly flammable gas that is lighter than air, is the by-product of battery charging. This gas is very easily ignited by low-energy sparks and so minimising the risk of it causing a fire or an explosion is a key feature of these requirements.

This can be achieved by making sure that batteries are stored in accordance with suppliers' recommendations. They should be secured in a ventilated area. The propulsion motor must also be securely installed. It is also important to ensure that your battery-charging equipment and controller compartments are adequately ventilated.

The risks of overheating cables and of not being able to quickly isolate a high-current circuit must also be addressed.

Boats obliged to meet BSS requirements must comply with the following:

12 All motors, controller equipment and charging equipment relating to electrical propulsion must be adequately ventilated.

8-11 All relevant requirements relating to electrical equipment as set out in Chapter 3 of this Guide must be complied with where applicable.

The following BSS general requirement is relevant to the securing of the engine:

1 All permanently installed fuel systems and fixed engines must be designed, installed and maintained in a way that minimises the risks of explosion or of fire starting or spreading.

4.1 Electrically propelled boats

The detail of the risks and ways to help reduce those risks for all electrical supply installations are set out in Chapter 3.

Fires can be caused by sparks igniting flammable gases or by cables overheating.

Hydrogen and air can be a very explosive mixture, especially towards the end of a charging cycle when significant quantities of hydrogen can be given off by the bank of batteries.

4.1.1/R REQUIREMENT

Is the electrical-propulsion supply system compliant with Chapter 3 as applicable?

Identify boats having an electrical propulsion system.

Apply all of Chapter 3 to the electrical supply system.

The electrical supply systems on all electrically propelled boats must comply with the applicable Chapter 3 BSS requirements.

Best practice

If the propulsion-system batteries are connected to a charging source that has a maximum charge rate in excess of 2kW (approx. 150 A at 13.8 V), we strongly recommend installing a fan-assisted ducted ventilation system. The fan's motor is best placed externally to the duct and battery space to avoid any potential for spark ignition. The fan should operate automatically during charging and run for an hour after charging is completed. We also recommend that its safe operation be checked by a competent person on a routine basis.

b

4.2 Electrical propulsion motor and controller

This section addresses the risks specifically linked to electric propulsion motors.

If electrical connections are damaged by excessive movement, they can cause a spark, which may start a fire or ignite nearby flammable fuels.

4.2.1/R REQUIREMENT

Are all parts of the electric-propulsion motor-mounting systems secure and in good condition?

Check electrical-propulsion motor-mounting systems for condition and completeness where they can be seen or reached.

Apply light manual force to check the extent of outboard motor movement beyond that allowed by the use of any flexible mounts.

Electrical-propulsion motor-mounting systems must:

- show no signs of fractured engine mounting brackets; **and**,
- not have loose, missing or fractured bolts or nuts; **and**,
- show no evidence of significant breakdown of any flexible mounts.
- show no signs of damaged, rusted or rotten motor bearers.

Electric outboard motors must be securely mounted so that there is no movement in any direction at the mounting points.

Notes – The check for condition and completeness includes mounting systems to electric outboard motors.

Do not apply light manual force to electric outboard motors you assess to be too heavy to move.

The risk of the motor and controller equipment overheating must be minimised.

4.2.2/R REQUIREMENT

Is the motor and controller equipment adequately ventilated and in good condition?

Check for any means to dissipate heat from the motor and controller equipment.

Check the condition of the motor and controller equipment.

Electric-propulsion motor and controller equipment spaces must be adequately ventilated by:

- the volume of the space being 10 or more times greater than the volume of the equipment; or,
- having ventilation provided.

Electric-propulsion motor and controller equipment must be free of:

- any obviously missing components; **and**,
- signs of damage and deterioration; **and**,
- signs of overheating on the equipment and the surrounding surfaces.

4.3 Battery-charging equipment

Battery-charging circuits can produce large amounts of heat and have the risk of components or wiring overheating, leading to shorting and/or fire.

Charging equipment that is 'open', damaged or incomplete could lead to a short-circuit or overheating. It may also be a potential source of harm for people aboard the boat.

4.3.1/R REQUIREMENT

Is the battery-charging equipment ventilated, complete and in good condition?

Check for any means to dissipate heat from the battery-charging equipment.

Check the condition of battery-charging equipment.

Battery-charging equipment compartments must be adequately ventilated by:

- the volume of the space being 10 or more times greater than the volume of the equipment; or,
- having ventilation provided.

Battery-charging equipment must be free of:

- any obviously missing components; **and**,
- signs of damage and deterioration; **and**,
- signs of overheating on the equipment and the surrounding surfaces.

Note – This check does not require the removal of covers provided by the equipment manufacturer.

Best practice

To minimise the risk of overheating cables, or short circuits, we recommend fitting a manually operated switch that isolates the battery charger from the incoming A.C. supply.

It is also a good idea to have an indicator light on your charging panel that shows when the boat's batteries are charging.

b

4.4 Battery-charger connection

Fires can be caused by overheated cables, which can occur if the cables do not have adequate capacity for carrying the current.

Best practice

To reduce the risk of this happening, maintain the cable, including the connectors from the battery charger on the boat to the charging point on shore, in good condition. We recommend that the charging cable is a suitable three-core flexible cable of adequate current-carrying capacity and of suitable construction and grade.

To avoid the risk of electric shocks or electrocuting people around you, we recommend that the charging connection on the craft itself has male (pins) configuration. This will ensure that the live charge lead will have female configuration and will not have exposed pins.

To protect the cables from water damage, we recommend that connectors comply with the splash-proof category of BS EN 60309 Part 2. Having splash-proof cable connections will greatly reduce the risk of electric shocks.

b

Charging connection - male pins on the boat's connector will help prevent electrocution.



5

Outboard and portable combustion engines and portable fuel systems

The Boat Safety Scheme Essential Guide



For more technical information

The requirements in this chapter have been informed by, and may refer to, the following technical references, codes and regulations. If you are building, fitting-out or making substantial changes to a vessel, we strongly recommend you refer to, and take account of, the codes and regulations below:

- **LP Gas Association Code of Practice 18 'Recommendations for the safe use of LPG as a propulsion fuel for boats, yachts and other craft'**
- **SRO 1929 No. 952 'The Petroleum Spirit (Motor Vehicles etc.) Regulations 1929'**
- **Statutory Instrument 1982 No. 630 'The Petroleum Spirit (Plastic Containers) Regulations 1982'**



BSS Essential Guide

This chapter covers outboard motors, generators and other portable engines. Carrying portable fuel tanks and transferring fuel can be hazardous if care is not taken – for example, petrol vapourises very readily during refuelling and can ignite very easily. Other fuels bring their own risks and they should be handled with equal care. This chapter complements Chapter 2 (Fixed fuel systems and permanently installed engines) and reflects the particular hazards related to portable engines and their fuels on boats.

You can minimise the risks associated with escaping fuels by ensuring that fuel does not enter the interior of your boat, and that all components including portable fuel tanks and spare fuel containers, are suitable for the fuel used. Keeping these in good condition and securely stowing the fuel containers will also reduce the risk of fuel spillage.

An important preface on the nature of petrol

Petrol is very volatile, that is, it evaporates quickly generating highly flammable vapours. A small spill of petrol will create a large amount of vapour. Likewise, when it is being transferred and especially when a tank is being filled, the vapour in the ‘empty’ tank is displaced by the new liquid fuel. Even if the concentration of vapour is too rich to burn immediately, it will dilute to flammable or explosive levels, even though, given enough ventilation, it may dissipate to a safe level eventual.

Petrol vapour is three to four times heavier than air. It will sink to the lowest level of its surroundings, accumulating at low level in places such as unventilated bulkheads, lockers and bilges or in enclosed spaces such as the cabins and cockpits of boats.

There is good advice on safe refuelling, use and stowage of petrol in our leaflet ‘Avoiding Fire Afloat – Safe Use of Petrol’.



All boats fitted with, or carrying, outboard or portable engines, whether they are in use or not, must comply with the following:

- 13** All portable and outboard engines and portable fuel systems must be designed, installed and maintained in a way that minimises the risks of explosion or of fire starting and spreading.

- 14** All spare petrol must be stored in a way that minimises the risk of fire and explosion.

- 15** All portable and outboard engines with integral petrol or LPG tanks, and all portable petrol tanks, must be stored in a way that minimises the risks of fire or explosion when not in use.

5.1 Portable fuel systems

Fixed fuel systems for outboard/power boats

The risks and requirements associated with fixed systems feeding liquid fuel or LPG to outboard or portable engines are set out in Chapters 2 and 7.

5.1.1/R REQUIREMENT

Do fixed fuel systems supplying outboard and portable combustion engines comply with the applicable BSS requirements for the fuel supply system?

Identify fixed fuel systems supplying outboard and portable combustion engines.

Apply the relevant Part of the BSS requirements to the fixed fuel system.

Fixed fuel systems supplying outboard and portable combustion engines must be compliant with the applicable BSS requirements of Chapter 2 or Chapter 7.

Note – LPG-fuelled outboard engine fuel installations are assessed by special arrangement with the BSS Office. See Checklist Item 5.5.1.

Using components that are unsuitable for the fuel in use and/or not designed for the rigours of the marine environment can lead to leaks and failures. Garden water hose, or hose connections secured with a wire twist are glaring examples of unsuitability.

5.1.2/R REQUIREMENT

Are all components of portable fuel systems of suitable proprietary manufacture?

Check the type of all components of portable fuel systems including the tank, fuel hose and priming bulb, and hose connections.

Verify components not identified as of suitable proprietary manufacture, if necessary by examining any presented declaration from the manufacturer or supplier.

Portable fuel system components must be of suitable proprietary manufacture, for example:

- tanks must be designed to store petrol and permit convenient carrying and removal for refilling outside the vessel;
- hoses and other fuel components must be intended for use with petrol;
- hose connections must be secured with proprietary clamps, clips or ties.

Portable fuel system components not identified to be of suitable proprietary manufacture must be supported by an appropriate declaration from the manufacturer or supplier.

Note – Where components cannot be verified as being of suitable proprietary manufacture, they will be considered as not meeting the requirements until suitability can be verified.

Here we consider the potential for fuel to escape during use. Damage to the fuel supply system and deterioration may lead to small, unseen leaks or catastrophic failure during use.

5.1.3/R REQUIREMENT

Are all components of portable fuel systems complete and in good condition?

Check the completeness and condition of all portable fuel system components including the tank, fuel hose and priming bulb, and hose connections.

Check the completeness and condition of support structures and fixings on transom-mounted tank arrangements.

Portable fuel systems must be complete including the fuel tank cap, the hose, and hose clamps/clips.

Components of portable fuel systems must be free of leaks and signs of damage or deterioration.

Portable fuel tanks must be free of signs of significant pitting or repairs on metal tanks, or corrosive attack or repairs on plastic tanks.

The support structures and fixings on transom-mounted tank arrangements must be complete and free of signs of damage or deterioration.

Notes – All surfaces and seams on components, including tank undersides, should be examined.

Supplementary information on assessing deterioration of plastic fuel tanks is available on www.boatsafetyscheme.com or by post or email from the BSS Office.

Information

During a BSS examination or other inspection, particular attention will be paid to the underside of the portable fuel tank and so we recommend regular checks on the tank's condition.



An uncontrolled escape of fuel could lead to a significant build-up of flammable vapours and the risk of fire or explosion.

5.1.4/R REQUIREMENT

Are portable fuel systems fitted with a means of shutting off the fuel supply?

Check all portable fuel systems for the means of shutting off the fuel supply between the tank and the engine.

A means of shutting off the fuel supply between the tank and engine must be fitted to all portable fuel systems.

Note – Acceptable shut-offs include a valve, cock or proprietary self-closing connector.

Information

If a small amount of fuel escapes overboard, during refuelling it will be naturally diluted. If large quantities of fuel or other substances escape into a waterway you should contact the Environment Agency/Scottish Environment Protection Agency Pollution Hotline on 0800 80 70 60 (24hrs).



5.2 Portable petrol tanks

In the BSS context, a portable fuel tank is one that can be carried on and off the boat and is designed to be connected by flexible piping directly to the engine. A close-coupled fuel tank forms an integral part of the engine.

There are limits on the size of petrol containers. Carrying too much petrol in one oversize tank can be difficult to handle safely without a risk of dropping or knocking the container. If you need a larger tank than this, it must be permanently installed and comply with the appropriate requirements in Chapter 2.

5.2.1/R REQUIREMENT

Does the maximum capacity of individual portable petrol tanks permit convenient carrying and removal for refilling outside the vessel?

Check the capacity of portable petrol tanks as marked on the tank.

The maximum capacity of portable petrol tanks must permit convenient carrying and removal for refilling outside the vessel.

The maximum capacity of portable petrol tanks must not exceed 27 litres (6 gal).

Notes – In the event the maximum capacity is not marked, assess the tank for obvious overcapacity. [1litre (approx ¼ gal) is equal to a cube 100mm x 100mm x 100mm (4in x 4in x 4in)].

Existing proprietary makes of portable petrol tanks of up to 30-litre (6½ gal) capacity are acceptable.

Stowed portable petrol tanks could present a risk of vapour flowing into the interior of the boat.

Self-adhesive reminder labels with the legend ‘Refuel ashore – never on board’ are available free of charge from the BSS Office. You are strongly recommended to fit them to all portable engine petrol tanks and spare petrol containers on board your vessel.



Highly Flammable vapour

**Refuel ashore
never
on board**

Boat Safety Scheme

www.boatsafetyscheme.com

5.2.2/R REQUIREMENT

Are all portable petrol tanks stored, when not in use, to ensure that any leaking fuel or escaping vapour will not enter the interior of the vessel?

Check the storage location of portable petrol tanks not connected to the engine.

Portable petrol tanks, which are not connected to the engine, must be stored in the open where any leaked petrol would flow overboard unimpeded, or in suitable locker.

Any locker used to store spare petrol must be:

- drained to the outside from the bottom; **and**,
- secure and constructed of a material of the required thickness, in good condition; **and**,
- free from objects that could block the drain, damage the petrol container or cause petrol vapour to ignite; **and**,
- fuel-tight to an equal or greater height than the top of the cap for the petrol container; **and**,
- self-draining and the drain hole must have a minimum internal diameter of 12mm (½ in) and must not be blocked; **and**,
- the locker must not open into any engine, battery or electrical equipment space; **and**,
- the drain line material including connections must be complete and in good condition.

Note – these are identical storage arrangements for LPG cylinders the detail of which is to be found in Chapter 7, sections 7.1–7.5.

Best practice

We recommend that you mark clearly the type of fuel contained in any portable fuel tanks on your boat. The wrong fuel may stop your engine from working and in certain situations, e.g. tidal and other waterways with strong currents, the loss of engine power could put you in danger.

b

5.3 Spare fuel containers

In the BSS context, a spare fuel container is one that can be carried on and off the boat and is designed to store spare fuel. A spare fuel container is not connected by piping to the engine.

Stowed spare fuel containers could present a risk of vapour flowing into the interior of the boat.

5.3.1/R REQUIREMENT

Are all spare petrol containers stored to ensure that any leaking fuel or escaping vapour will not enter the interior of the vessel?

Check the storage location of spare petrol containers.

Spare petrol containers must be stored in the open where any leaked petrol would flow overboard unimpeded, or in suitable locker.

Any locker used to store spare petrol must be:

- drained to the outside from the bottom; **and**,
- secure and constructed of a material of the required thickness, in good condition; **and**,
- free from objects that could block the drain, damage the petrol container or cause petrol vapour to ignite; **and**,
- fuel-tight to an equal or greater height than the top of the cap for the petrol container; **and**,
- self-draining and the drain hole must have a minimum internal diameter of 12mm (½ in) and must not be blocked; **and**,
- the locker must not open into any engine, battery or electrical equipment space; **and**,
- the drain line material including connections must be complete and in good condition.

Note – these are identical storage arrangements for LPG cylinders the detail of which is to be found in Chapter 7, sections 7.1–7.5.

The use of unsuitable containers to store petrol could lead to petrol leaking into the boat or the fuel not being correctly recognised by another person. UK law governs the carriage of spare petrol and limits the amount of spare petrol you may carry.

5.3.2/R REQUIREMENT

Are all spare petrol containers suitable for the purpose and limited to the permitted volume?

Check the type and capacity of spare petrol containers.

The amount of spare petrol carried is limited to any combination of the following containers:

- 2 x 10 litre (2 gal) metal containers marked to conform with the 1929 Petroleum Spirit Regulations;
- 2 x 5 litre (1 gal) plastic containers marked to conform with the 1982 Petroleum Spirit Regulations;
- 1 x portable petrol tank of suitable proprietary manufacture of up to a maximum capacity of 27 litres (6 gal).

Notes – The carriage of spare diesel or paraffin is not restricted by volume.

An existing proprietary make of portable petrol tank of up to 30-litre (6½ gal) capacity is acceptable.

Best practice

We strongly recommend that for storing fuels other than petrol, you use only the containers suitable for the fuel type as recommended by the manufacturer.



Information

The amount of petrol and the conditions under which it is stored at home and transported to your boat is covered by various regulations. These may differ in important respects from the BSS requirements. You can find out more information from your local fire and rescue service or your local authority.



A tank in poor condition could soon leak or fail completely, allowing vapour to build up to dangerous levels.

5.3.3/R REQUIREMENT

Are all spare fuel containers in good condition?

Check the condition of spare fuel containers.

Spare fuel containers must be free of signs of significant pitting or repairs on metal tanks, or corrosive attack or repairs on plastic tanks and must be free from leaks and other signs of damage or deterioration.

Notes – This check covers spare petrol, spare diesel and paraffin containers.

Close attention should be paid to the underside of spare fuel containers.

Supplementary information on assessing deterioration of plastic containers is available on www.boatsafetyscheme.com or by post or email from the BSS Office.

5.4 Outboard and portable combustion engines

Fuel system components on outboard and portable engines can present the same potential hazards as main fuel and spare fuel containers.

A fuel or gas escape into your boat from any part of your portable engine or generator would be a serious hazard.

5.4.1/R REQUIREMENT

Are all outboard and portable combustion engines free of fuel leaks?

Check for the presence of leaking fuel on or around all outboard and portable combustion engines.

Outboard and portable combustion engines must be free of obvious signs of fuel leaks.

Note – this check does not require the removal of outboard covers or generator hush covers.

5.4.2/R REQUIREMENT

Are all outboard and portable combustion engines with integral petrol or LPG tanks stored to ensure that leaking fuel or escaping vapour will not enter the interior of the vessel?

Check the storage location of outboard engines with integral petrol tanks and portable combustion engines with integral petrol or LPG tanks.

Outboard engines with integral petrol tanks and portable combustion engines with integral petrol or LPG tanks must be stored in the open where any leaked petrol would flow overboard unimpeded, or in suitable locker.

Any locker used to store spare petrol must be:

- drained to the outside from the bottom; **and**,
- secure and constructed of a material of the required thickness, in good condition; **and**,
- free from objects that could block the drain, damage the petrol container or cause petrol vapour to ignite; **and**,
- fuel-tight to an equal or greater height than the top of the cap for the petrol container; **and**,
- self-draining and the drain hole must have a minimum internal diameter of 12mm ($\frac{1}{2}$ in) and must not be blocked; **and**,
- the locker must not open into any engine, battery or electrical equipment space; **and**,
- the drain line material including connections must be complete and in good condition.

Notes – Outboard or portable combustion engines that are not stored, e.g. those that are running or connected, are not covered by this check.

These are identical storage arrangements for LPG cylinders the detail of which is to be found in Chapter 7 sections 7.1–7.5.

An insecurely mounted engine can lead to part of its fuel supply system becoming detached and fuel escaping with the potential to spread a fire or cause an explosion.

5.4.3/R REQUIREMENT

Are outboard engine mounting systems in good condition?

Check the condition of outboard engine mounting systems.

Assess the extent of any movement by applying light manual force to the outboard engine.

Outboard engines must be securely mounted so that there is no movement in any direction at the mounting points.

Mounting systems must be free of signs of damage or deterioration.

Note – Do not apply light manual force to engines that are too heavy to move.

Best practice

In addition to the normal mounting, we recommend you fit a security lanyard or wire from the engine to a secure eyebolt or bracket inboard of the engine.

b

5.5 LPG-fuelled outboard propulsion engines

The incorrect installation of fuel supply arrangements to LPG-fuelled outboard engines may lead to LPG exploding and a fire. On dual fuel petrol/LPG installations there is a risk of damaging carburettor components, which could cause a petrol vapour explosion.

5.5.1/R REQUIREMENT

Do the fuel supply arrangements to LPG-fuelled outboard engines comply with LPGA CoP 18 and are any dual-fuel petrol/LPG arrangements of an acceptable type?

[LPG-fuelled outboard engines can only be checked for compliance by prior arrangement by the owner with the BSS Office.]

Check the fuel supply type to outboard engines and identify those fuelled by LPG or dual-fuel petrol/LPG.

The fuel supply arrangements to LPG-fuelled outboard engines must comply with LPGA Code of Practice (CoP) 18.

Any dual-fuel arrangements must be installed and maintained accordance with the engine manufacturer's guidelines for marine applications.

Notes – When planning a BSS examination, owners of LPG-fuelled outboard engines are advised to contact the BSS Office to arrange for an examiner who is competent to apply LPGA CoP 18, to undertake a full examination of the boat.

Examiners may determine compliance of portable LPG-fuelled generators to applicable BSS requirements.

6

Fire extinguishing and escape

The Boat Safety Scheme Essential Guide



For more technical information

The requirements in this chapter have been informed by, and may refer to, the following technical references, codes and regulations. If you are building, fitting-out or making substantial changes to a vessel, we strongly recommend you refer to, and take account of, the codes and standards below:

- **BS 5306-3:2003 'Fire extinguishing installations and equipment on premises. Code of practice for the inspection and maintenance of portable fire extinguishers'**
- **BS 5499-2:1986 'Fire safety signs, notices and graphic symbols. Part 2 Specification for self-luminous fire safety signs'**
- **BS 5499-5&6:2002 'Graphical Symbols and Signs. Safety Signs, Including Fire Safety Signs – 'Part 5: Signs with Specific Safety Meanings' 'Part 6: Creation and design of graphical symbols for use in safety signs'. Requirements**
- **BS 6575:1985 'Specification for fire blankets' (superseded, withdrawn)**
- **BS EN 3-6:1996 'Portable fire extinguishers. Provisions for the attestation of conformity of portable fire extinguishers in accordance with EN 3 Pt 1 to Pt 5'**
- **BS EN 1869:1997 'Fire blankets'**



BSS Essential Guide

- BS EN ISO 9094–1:2003 ‘Fire Protection. Craft with a hull length of up to and including 15m’
- BS EN ISO 9094–2:2002 ‘Fire Protection. Craft with a hull length of over 15m and up to 24m’
- Statutory Instrument SI 1998 No. 1011 ‘The Merchant Shipping (Fire Protection: Small Ships) Regulations 1998’
<http://www.opsi.gov.uk/si/si1998/19981011.htm>
- MCA Information on the ‘Regulations Applicable to Pleasure Vessels’ http://www.mcga.gov.uk/c4mca/mcga-pleasure_craft_information_pack.pdf

This chapter covers the requirements to ensure that your boat has suitable fire-fighting equipment in order to provide an immediate response to a small fire. This will minimise the risk of a fire on your boat escalating out of control, and can help you and your passengers to escape safely.

You should ensure that your portable fire extinguishers are properly certified, that you have a sufficient number of an appropriate type and that they are in good condition. A fire blanket may provide a better method of extinguishing a cooking pan fire. There is a section on fire blankets in this chapter.

To help ensure that anyone onboard may escape more easily from a fire, we strongly recommend that whenever possible, your boat should have two means of escape from accommodation areas. This will be checked at examination and advice provided as appropriate.

Knowing about the location of your extinguishers, how to use them and the fire blanket and ensuring your crew know where the escape points are key parts of a fire action plan. There is more information on making a fire action plan in our leaflet ‘Avoiding Fire Afloat’.



Boats obliged to meet the navigation authorities' requirements must comply with the following:

- 16** All vessels must carry specified fire fighting equipment.
- 17** All fire fighting equipment must be maintained in good condition and kept readily accessible for safe use in an emergency.

6.1 Portable fire extinguishers

Having the equipment to deal with small fires as well as the facility to aid an escape from a small fire is covered in this section.

The size and layout of a boat determines your ability to reach an extinguisher easily and to have the available capacity to control small fires.

6.1.1/R REQUIREMENT

Are the correct number of portable fire extinguishers provided, and do they have the correct fire ratings?

Check the number of portable fire extinguishers provided and check their individual and combined fire ratings.

Each portable fire extinguisher must have an individual fire rating of 5A/34B or greater.

The number of portable extinguishers and their combined fire ratings, must be as prescribed in the following table.

The minimum number of extinguishers may be reduced by a maximum of one 5A/34B rated extinguisher where the vessel has either no internal combustion engines, or no fuel-burning appliances.

Length of vessel	Min. number of each	Min. combined fire rating
Under 7m (23ft)	2	10A/68B
7-11m (23-36ft)	2	13A/89B
Over 11m (36ft)	3	21A/144B

Notes – Owners of longer vessels must pay attention to the total required capacity in the ‘Min. combined fire rating’ column.

Portable fire extinguishers manufactured prior to the introduction of EN 3 may not have fire ratings marked on the extinguisher. Such extinguishers maintained in good condition, properly certified and satisfying the navigation authority’s previous individual and total weight requirements are acceptable. More information about this is available on www.boatsafetyscheme.com or by post or email from the BSS Office.

Fuel-burning appliances include those fuelled by LPG, diesel, paraffin, spirit and solid fuel.

Supplementary information on fire ratings and classification is available on www.boatsafetyscheme.com or by post or email from the BSS Office.

Poor quality of design or manufacture could mean you do not have a working extinguisher when you most need it. The navigation authorities need to be assured of an extinguisher's performance and seek independent verification.

6.1.2/R REQUIREMENT

Is the performance of all the portable fire extinguishers properly certificated?

Check all portable fire extinguishers, identified as being compliant at 6.1.1, for evidence of accredited third-party certification.

Portable fire extinguishers must be marked with at least one of the following certification marks:



British Approvals for Fire Equipment



Loss Prevention Certification Board



Loss Prevention Certification Board



Société Générale De Surveillance



British Approvals for Fire Equipment



AFNOR 'NF' mark



Marine Equipment Directive 'ship's wheel'

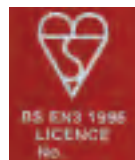

British Standards Institution 'Kitemark'

Notes – 'CE' marking alone on any extinguisher does not indicate certification of performance to EN 3. Further information is available on www.boatsafetyscheme.com or by post or email from the BSS Office.

Firemaster 1000PR B/C [Brass/Chrome] models marked without the 'Kitemark' are acceptable.

Can you be confident about the working condition of your extinguishers? An extinguisher in poor condition may suffer pressure loss, contents loss, mechanism failure or other reasons for not working.

6.1.3/R REQUIREMENT

Are all portable fire extinguishers in good condition?

Check the condition of all portable fire extinguishers identified as compliant at 6.1.1 and 6.1.2.

Portable fire extinguishers must be in good general condition, and must not show any of the following indicators of poor condition:

- missing safety pin;
- dents;
- gouges;
- pressure gauge (where fitted) indicator in the 'red' sector;
- having passed the manufacturer's express 'expiry' or 'replace by' date;
- perished hose;
- significant rust or other form of corrosion;
- obvious under weight indicating whole or partial discharge;
- signs of damage to trigger assembly, including deterioration caused by ultraviolet light and heat.

Notes – Portable fire extinguishers having passed the manufacturer's express 'expiry' or 'replace by' dates are acceptable if supported by evidence of servicing in accordance with BS 5306 by a service technician within the last 12 months. Evidence must be in the form of a service label on the extinguisher and an associated invoice or service report on headed paper from a company recognisable as an extinguisher servicing company.

Best practice

We recommend all extinguishers of a serviceable type have an annual service by a suitably competent person.

We recommend using companies and technicians registered with the body known as BAFE to be assured of fire extinguisher servicing standards.

b

The correct installation of your extinguishers is crucial. In the event of a fire on your boat, extinguishers that are not easy to reach quickly, may be useless.

6.1.4/R REQUIREMENT

Are portable fire extinguishers distributed around the vessel in readily accessible and safe locations adjacent to escape routes?

Check the accessibility and location of the portable fire extinguishers identified as compliant at 6.1.1 and 6.1.2.

Portable fire extinguishers must be readily accessible.

Portable fire extinguishers must be distributed around the vessel adjacent to escape routes.

Portable fire extinguishers must not be mounted in a position that requires the user to reach over a cooking appliance.

Best practice

We strongly recommend mounting portable fire extinguishers on fixed brackets to aid their more rapid use.

b

You may prefer to locate extinguishers in lockers for reasons of security, ease of passage, etc. In the event of a fire, people unfamiliar with your boat including the emergency services, need to locate extinguishing equipment quickly.

6.1.5/R REQUIREMENT

Are all portable fire extinguishers in open view or their location clearly marked?

Identify the location of all portable fire extinguishers identified as compliant at 6.1.1 and 6.1.2.

Where portable fire extinguishers are not in open view with all removable lids, doors, curtains, etc in place, check for the presence of a label in open view indicating their location.

Portable fire extinguishers, must:

- be in open view with all removable lids, doors, curtains etc in place; or,
- have their location clearly marked by a label in open view.

Notes – the location of any fixed portable fire extinguisher brackets may be used to determine the normal location of any extinguishers found lying loose at the time of an examination.

Where used, the preferred label has a red background and white image (off-white for luminous items) of a portable fire extinguisher. A few design examples of proprietary labels are shown below. Such labels in the form of stickers or sign-plates, may be available from local chandlers, internet based sign-suppliers, builders merchants, ironmongers, DIY stores, etc.



Landscape with text



Plain icon



Square, icon only



Portrait with text



Landscape with additional warning



Luminous (glow in dark)

6.2 Fire blankets

Extinguishers are not always the most suitable means to control or put out a fire. With pan fires, a fire blanket will be better than most extinguishers, indeed you may spread burning oil by using some types of extinguisher.

6.2.1/R REQUIREMENT

If the vessel has permanent cooking facilities, is a fire blanket of the correct specification provided?

Check for the presence of permanent cooking facilities and, if present, check for the provision of a fire blanket.

If permanent cooking facilities are present a fire blanket marked to indicate conformity to BS EN 1869, or to the 'light duty' requirements of BS 6575, must be provided.

Notes – a fire blanket is not required if a microwave oven is the only permanent cooking facility.

The occasional use of space heater stoves for cooking does not require the provision of a fire blanket.

If your fire blanket is not easily and quickly accessible, it may not be of any use.

6.2.2/R REQUIREMENT

Is the fire blanket located close to the main cooking appliance in a safe and ready-to-use location?

Check the location of the fire blanket.

Fire blankets must be located in a readily accessible position within approximately 2m (6ft 6in) of the main cooking appliance, and not mounted in a position that requires the user to reach over the cooking appliance.

Best practice

We strongly recommend having the fire blanket mounting permanently fixed to aid the blanket's more rapid use in an emergency.

b**Information**

A fire blanket can also aid escape by shielding you or somebody else from the fire.

i

6.3 Emergency escape

The examination will include advice on your boat's escape routes.

Your safety, that of your crew and that of visitors to the boat is in your hands, but we will offer you some information and advice to help you with that responsibility. To that end we bring to your attention the risks of having only one escape route from your boat. One escape route can easily be blocked by fire with the potential to trap someone within a burning boat.

6.3.1/A ADVICE

Is the vessel provided with adequate means of escape?

Check each accommodation space for the means to escape.

Measure the minimum dimensions of clear openings used as a means of escape such as hatches, windows or ports.

If a fixed window or port is designated an escape route, check that a means of 'breaking-out' is present.

Each accommodation space is recommended to have at least two means of escape.

The recognised minimum clear opening for a means to escape is 0.18m² (279 in²) and all openings must accommodate a 380mm (15 in) diameter circle.

A means of 'breaking out' any fixed window or port designated as an escape route can only be recognised if it is stored adjacent to it.

Notes – At the time of examination, if two means of escape meeting the minimum recommendations cannot be identified; the examiner will record what was found and alert you so that you are aware of this important safety issue that may affect yourself and your crew.

Best practice

If a window or hatch is the secondary means of escape, we recommend using a suitable proprietary fire or emergency exit label to identify it. It may help people not familiar with your boat to escape in an emergency.

b

Information

If the introduction of a second means of escape involves cutting or removing structural members, e.g. deck beams, frames or stiffeners, owners are advised to seek professional advice from the boat builder, supplier or a professional marine surveyor before commencing work.

i

Best practice

With regard to polystyrene thermal insulation, soft furnishings, fabrics and foam filling materials, we recommend checking with your supplier or the manufacturers' statements that any such material meets the latest national or international standards for fire-resistance, and for release of smoke and toxic gases in fires.

b

7

LPG installations

The Boat Safety Scheme Essential Guide



For more technical information

The requirements in this chapter have been informed by, and may refer to, the following technical references, codes and regulations. If you are building, fitting-out or making substantial changes to a vessel, we strongly recommend you refer to, and take account of, the codes and standards below:

- **BS 669:1997 'Flexible hoses, end fittings and sockets for gas burning appliances'**
- **BS 3212:1991 'Specification for flexible rubber tubing, rubber hose and rubber hose assemblies for use in LPG vapour phase and LPG/air installations'**
- **BS EN 1763-1:2001 'Rubber and plastics tubing, hoses and assemblies for use with commercial propane, commercial butane and their mixtures in the vapour phase'**
- **BS EN ISO 7840:2004 'Small craft. Fire-resistant fuel hoses'**
- **BS EN ISO 10239:2000 'Small craft. Liquefied petroleum gas (LPG) systems'**
- **PD 5482-3:2005 'Code of practice for domestic butane and propane gas-burning installations – Part 3: Installations in boats, yachts and other vessels'**
- **Statutory Instruments 1998 No. 2451 'The Gas Safety (Installations and Use) Regulations 1998'**
(www.hmso.gov.uk/si/si1998/19982451.htm#end)
- **Calor Gas: 'LPG (Bottled Gas) for Marine Use'**



BSS Essential Guide

LPG (Liquefied Petroleum Gas) is kept under pressure as a liquid and when released, becomes a highly flammable gas that is much heavier than air. The gas industry also knows it as one of the most searching of gases, that is, it can escape through gaps that would hold water and other gases.

This chapter explains how to minimise the risk of LPG escaping into your boat's interior, where it could quickly build up from the bottom of the boat forming an explosive 'mix' of gas and air. Therefore, we explain in this chapter how you must store LPG, how to arrange the gas supply system and how to protect the gas supply installations from heat and impact damage.

This chapter covers the reasons for shut-off valves and appliance isolation valves to control the LPG supply, and the importance of having the system installed in a way that minimises risk. We strongly recommend that any work on LPG systems be carried out by a suitably competent person. We further recommend reading our leaflet 'Avoiding Fire Afloat – Safe Use of LPG' which has useful advice on staying safe when changing cylinders, what to do if you suspect a gas leak and some checks to help prevent emergencies.



Boats obliged to meet BSS requirements must comply with the following:

- 18** All LPG systems must be designed, installed and maintained in a way that minimises the risks of explosion or of fire starting and spreading.

- 19** All LPG containers and high-pressure components must be secured in a position where escaping gas does not enter the interior of the vessel.

- 20** All LPG systems must be designed, installed and maintained to ensure gas-tight integrity.

- 21** All LPG system connections and flexible hoses must be accessible for inspection.

- 22** All LPG control and shut-off devices, or the means to operate them must be readily accessible.
-
- 23** LPG shut-off valves, or their means of operation, must be marked when not in clear view or when their function is not clear.
-
- 24** All LPG systems must have a suitable means to test that the system is gas-tight.
-

An important preface on the nature of LPG

On boats, the Liquefied Petroleum Gases in common use are, 'commercial butane', and 'commercial propane'. They exist as gases at normal temperatures, but become a liquid under moderate pressure. Propane turns into gas at a lower temperature than butane, so the storage pressure for liquid propane is slightly higher than butane.

One volume of liquid butane or propane produces approximately 250 volumes of gas and thus a leak of liquid is a grave hazard, especially on a boat. Since LPG vapour is denser than air, leaked LPG vapour will fall and flow along cockpit floors, bilges, etc and the vapour may travel some distance. The LPG will build up in low-lying parts of your boat and it may persist for some time.

It only needs concentrations of 2–10% LPG in air to make a flammable mix. In a boat, a flammable mix will explode if ignited. It is also possible for gas/air mixtures from leaks or other causes to be ignited some distance from the point of leakage and the flames travel back to the source before exploding. In extreme cases, if the cylinder is lying on its side; if the cylinder valve is faulty; or if the exposure to the fire is extended, the cylinder may rupture leading to a violent explosion. Alternatively, the point could be reached where the pressure-relief valve releases LPG, causing a significant jet of burning gas.

To help prevent incidents, a stenching agent is added to give LPG a strong odour, which most people can smell long before the gas reaches dangerous concentrations.

[Based on information from the LP Gas Association]

LPG installation testing

All LPG installations must meet the gas-tightness testing requirements of PD 5482-3. Meeting these requirements will give an assurance that the installation is gas-tight at the time of the test. However, to minimise the risks of gas leaks into your boat, it is also critical that all maintenance and changes to LPG installations are carried out competently.

At the time of examination, it is very important to ensure that all appliances to be tested are in working order and that your boat has enough gas, water and electrical power on board for testing to take place. If appliances cannot be tested, the examination will be incomplete and, where this relates to a requirement, no certificate can be issued (see Chapter 1).

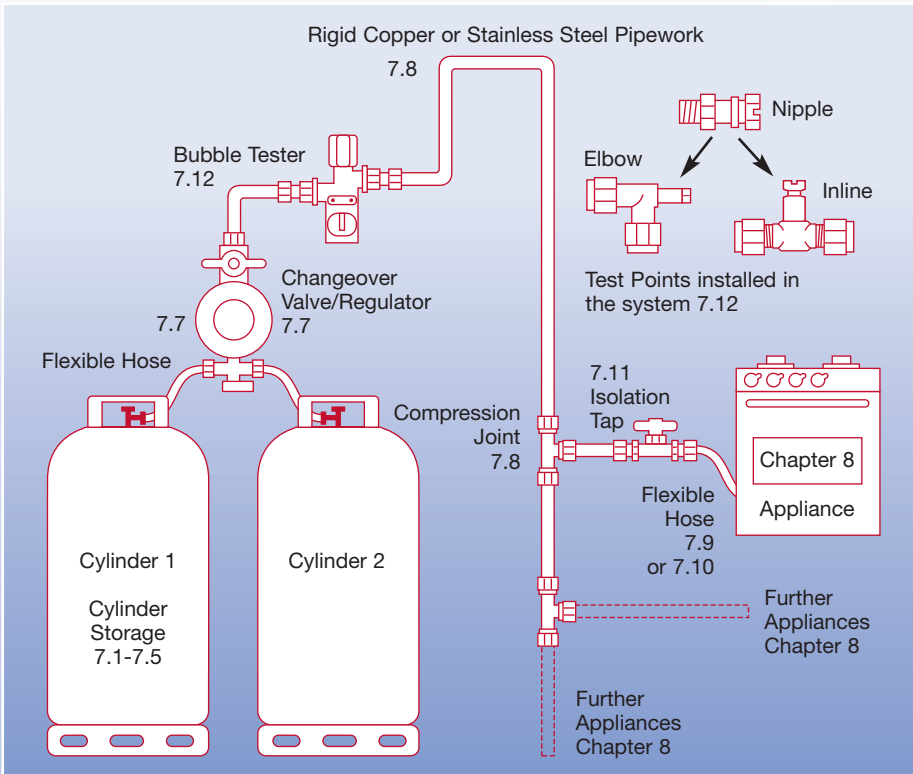

7.1 Location of LPG cylinders - escaped gas must drain overboard

This section deals with preventing escaped LPG building up inside your boat.

If located in the wrong place or in the wrong way damaged LPG cylinders, their valves, or fittings could cause gas to leak into your boat's interior. As it builds up, there will be a growing risk of it causing a fire or explosion.

7.1.1/R REQUIREMENT

Are all LPG cylinders and containers stored in a position where any leakage will be directed safely overboard?

Check for the presence of any LPG cylinders or containers. If present, check whether their location is in either a cylinder locker or an open location.

If located in a cylinder locker apply the checks at 7.2–7.5.

If located in an open location:

- identify the type of any cockpit storage location;
- check the location for any barriers to leaked LPG flowing overboard;
- check location for any openings into the interior of the vessel, or for any source of ignition, within 1m (39in) distance.

All LPG cylinders or containers, whether full, part full or empty must be stored either in a cylinder locker complying with the requirements of the Checklist Items in sections 7.2–7.5, or in an open location.

Cylinders stored in an open location:

- must be outside of a **non** self-draining cockpit or well deck; **and**,
- must be in a position where any leaked LPG would flow overboard unimpeded; **and**,
- must be where there is no opening into the interior of the vessel, or any source of ignition, within 1m (39 in) distance.

Notes – Cylinder housings may be used in open locations. Cylinder housings are ventilated enclosures intended solely for storage of one or more LPG cylinders, pressure regulators and safety devices and located on the exterior of the craft, where any leakage would flow overboard. [ISO 10239].

The storage arrangements of cylinders, not in cylinder lockers, stored in *self-draining cockpits* should be assessed against Checklist Item 7.2.4.

Sources of ignition include open-flame or spark-inducing equipment. Solenoid LPG system shut-off valves of suitable proprietary manufacture are presumed not to be a source of ignition. Outboard motors within 1m (39 in) of cylinders are **not** to be considered a source of ignition.

Best practice

b

Although it is compliant, we do not recommend storing cylinders and the high- and low-pressure connection and associated equipment on the outside face of the transom, owing to the risk of damage in the event of a collision. Should this arrangement be necessary, we recommend that components be adequately protected from potential collision damage.

Self-contained portable gas appliances, which have the burner screwed direct to the cylinder or container, such as a camping stove or lamp, still have the potential to leak sufficient amounts of LPG into the interior of a boat to create an explosive ‘mix’ even when the cylinder is apparently empty and any appliance valve is closed.

7.1.2/R REQUIREMENT

Are all self-contained portable LPG appliances stored so that any LPG leakage will be directed safely overboard?

Check for the presence of self-contained portable appliances having LPG cylinders or containers attached.

If present, apply the checks at 7.1.1.

All self-contained portable appliances having LPG cylinders or containers attached must be stored in accordance with the requirements of 7.1.1.

Note – this check applies to camping-style appliances but not items such as gas hob lighters.

Best practice

Supervise these appliances closely at all times when in use.

Dispose of empty cylinders or canisters safely and do not discard them in waste bins where leaking LPG would be a hazard.

b

7.2 LPG cylinders in a cylinder locker:

Cylinder lockers have many advantages as a place to stow LPG, but they must meet certain criteria to comply with the navigation authorities' requirements and national and international standards.

LPG is one of 'the most searching gases' and will escape quickly from any weak point.

7.2.1/R REQUIREMENT

Is the cylinder locker LPG-tight up to the level of the top of the cylinder valves or other high-pressure components?

Check the extent of the LPG-tight area of all LPG cylinder lockers.

Check the condition of all cylinder locker and housing bottoms and sides.

Cylinder lockers must be LPG-tight to the level of the top of the cylinder valves, **and** other high-pressure components where these are located higher than the valves.

Within the required LPG-tight area, the bottom, sides, and seams of every cylinder locker must be free of holes, cracks, damaged welds, significant corrosion, or other damage.

The above requirements also apply where any part of cylinder housing forms a part of the craft's hull or superstructure.

Note – The LPG-tightness of side-opening cylinder locker doors compliant with ISO 10239 is covered at 7.2.3.

Best practice

Lockers that open from the top or from the outside of the boat are easier to make and keep LPG-tight.

b

7.2.2/R REQUIREMENT

Are the sealing arrangements on pipework exiting the cylinder locker of the correct type to ensure LPG-tightness and in good condition?

Check the position, type and condition of sealing arrangements on pipework exiting cylinder lockers and housings.

Pipework must exit LPG cylinder lockers through either a bulkhead fitting, or cable gland fitting, or be above the LPG-tight level.

The sealing arrangements must be free of signs of damage and deterioration.

The above requirements also apply where any part of cylinder housing forms a part of the craft's hull or superstructure and where the LPG pipe exits the housing into the interior of the vessel.

Note – In the event the pipework exits the locker below the LPG-tight level through a conduit, it is acceptable that the pipework is protected by the effective use of sealant within the conduit.

Side-opening lockers can bring their own difficulties with ensuring an effective seal to the door or preventing gas from flowing into your boat's interior.

7.2.3/R REQUIREMENT

Are arrangements on side-opening cylinder lockers compliant with ISO 10239?

Check that the location of any side-opening locker door is outside of the interior of the vessel.

Visually check the condition of the door seals.

If the seals appear free of gaps, damage and deterioration, apply the check at 7.2.4.

If the seals appear free of gaps, damage and deterioration; and the arrangements do **not** satisfy the check at 7.2.4, call the BSS Office for further advice concerning conducting a smoke-pellet test.

Side-opening lockers must not be able to be opened from the interior of the vessel.

The seals of any side-opening cylinder locker door must be LPG-tight; **and**, must be free of signs of gaps in the contact with the locker body; **and**, must be free of damage or deterioration.

Door seals with no signs of gaps or damage must satisfy check 7.2.4 or pass the smoke-pellet test.

Note – If the arrangements on your boat do not meet the requirements set out in 7.2.3, the boat can still be compliant if it meets Checklist Item 7.2.4.

7.2.4/R REQUIREMENT

Do the arrangements in a self-draining cockpit prevent LPG entering the interior of the vessel?

Verify the cockpit is self-draining.

Verify the presence of LPG cylinders not in a cylinder locker.

If present, verify whether the self-draining cockpit arrangements prevent LPG entering the interior of the vessel by checking:

- the height of cockpit drain outlets in relation to the normal laden waterline; **and**,
- the height to which cockpit is LPG-tight; **and**,
- the condition of any hatches or openings, and associated seals, gaskets, below the height of the cylinders, regulators and associated equipment.

If the effectiveness of side-opening cylinder locker door seals cannot be verified, or if cylinders are stored in cylinder housings, then the arrangements of a self-draining cockpit must be as follows:

- the height of cockpit drain outlet(s) must be above normal laden waterline; **and**,
- the cockpit must be LPG-tight to the interior of the vessel at least to a height equal to that of the height of the top of the LPG cylinder valves and other high-pressure components where these are located higher; **and**,
- hatches or openings, and associated seals, gaskets, below the height of the LPG cylinder valves and other high-pressure components where these are located higher must be free of signs of damage or deterioration.

Notes – This Checklist Item is relevant to cylinders in self-draining cockpits where, either the side-opening cylinder locker door seal fails the test at 7.2.3, or cylinders are not stored in any enclosure or, cylinders are stored in a cylinder housing.

In the event that the arrangements comply with 7.2.3, the Checklist Item at 7.2.4 is not applicable.

7.3 Cylinder locker drains

This section considers the importance of having an effective drain for escaped gases in any cylinder locker.

If a blocked drain causes leaked gas to build up in your locker, there is a risk of it being ignited. Even comparatively small amounts of LPG can cause a serious explosion.

7.3.1/R REQUIREMENT

Is there a drain in the cylinder locker and is the drain outlet above the waterline?

Identify the presence of a drain in each cylinder locker.

Identify the cylinder locker drain outlet on the outside of the hull and verify that it is above the normal laden waterline.

All cylinder lockers must be fitted with a drain.

Cylinder locker drain outlets must be above the normal laden waterline.

7.3.2/R REQUIREMENT

Is the drain opening at or close to the bottom of the cylinder locker or is any volume beneath the drain-opening minimised by the use of suitable material?

Check the location of the cylinder locker drain-openings.

If the drain opening is above the bottom of the locker check that any area below the drain opening that could retain leaked LPG is filled with LPG-resistant material.

Cylinder locker drain-openings must be located at the bottom of the locker or at the lowest point of the side.

Any area in the cylinder locker below the drain that could retain leaked LPG must be filled with LPG-resistant material.

Note – Drain openings on the side of cylinder lockers not greater than 25mm (1 in) above the bottom of the locker may be considered as at the lowest point of the side.

7.3.3/R REQUIREMENT

Is the cylinder locker clear of any items that could block the drain?

Check cylinder lockers for any items that could block the drain.

Cylinder lockers must be clear of any item that could block the drain.

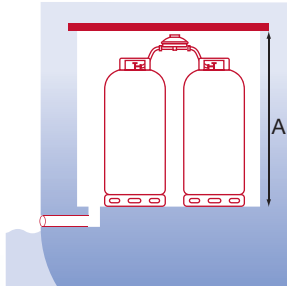

Bottom drain

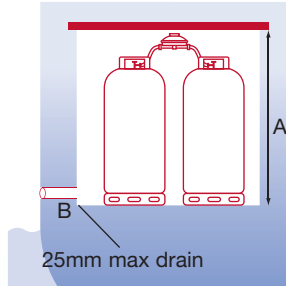

Side

25mm max drain

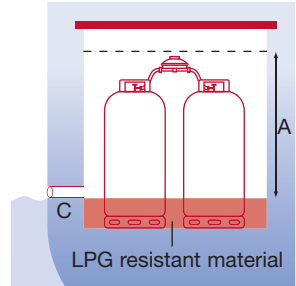

Bottom drain equivalent

LPG resistant material

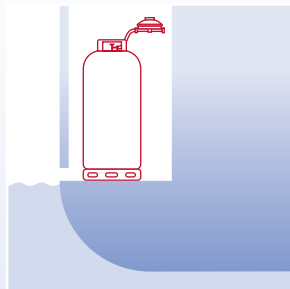

Direct Opening

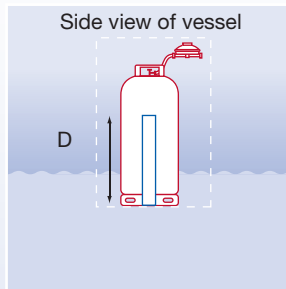

Side opening or series of holes

Side view of vessel

D

7.2 LPG-tightness and 7.3 cylinder locker drains

A. 7.2.1 Is it LPG-tight up to the top of the cylinder valves?

B. Side opening drain must comply with 7.3.2

C. Side opening drain below which is filled LPG-resistant material 7.3.2

D. Slit opening must comply with 7.3.6

7.3.4/R REQUIREMENT

Does the drain line fall continuously from the cylinder locker to the external connection and are both ends clear of blockage?

Check the completeness and fall of the drain line to the external connection where it can be seen.

Check the drain openings in the cylinder locker and at the external connection for obstruction.

Cylinder locker drain-lines must be continuous and must fall continuously to the external connection so as not to retain leaked LPG.

Drain openings in the cylinder locker and at the external connection must not be blocked.

Note – A bucket of water can be used to aid verification of Checklist Items 7.3.4–7.3.6. At examination, the examiner may ask your permission to use water to test the drain, if appropriate.

If the drain line material or connections deteriorate, this could cause LPG to enter the boat and cause an explosion or fire.

7.3.5/R REQUIREMENT

Is the drain line material, including the connections, in good condition?

Check condition of cylinder locker drain-line material that can be seen.

Check condition of all connections that can be seen.

Where connections can be reached, pull using light manual force to check security of all hose connections.

The material of drain lines must be in good condition and all connections must be complete and free of signs of damage or deterioration.

Drain hoses must be free of any signs of damage and deterioration, including 'soft' spots or kinking of the walls.

Drain hose connections made with hose clips or clamps must:

- be suitably sized, that is, not so oversized that the band forms an elliptical shape or so undersized that no tightness is achieved; **and**,
- be appropriately tight, that is, not so loose that the connection can be pulled forward or back under light manual force nor so tight that the hose is excessively pinched; **and**,
- show no signs of damage or deterioration at the clip or clamp; **and**,
- show no signs of damage or deterioration at the hose.

Best practice

We recommend you to fit, whenever possible, drain hose that complies with a recognised standard such as ISO 7840 for fire resistance or BS 3212 for LPG.

b

As the amount of LPG contained in the locker rises, so does the need for effective drainage.

7.3.6/R REQUIREMENT

Does the drain line, or the drain opening, have a minimum appropriate internal diameter or equivalent area?

Measure the internal diameter of each cylinder locker drain opening. Check the drain line that can be seen for no obvious reductions.

Cylinder locker drains must have a minimum internal diameter of 12mm (½ in) or increased pro-rata up to 19mm (¾ in).

Total cylinder capacity	Internal diameter of drain opening or equivalent area	
1-18kg	12mm (½ in)	113mm ²
19-29kg	14mm (⅝ in)	154mm ²
30-37kg	17mm (⅝ in)	227mm ²
38kg or greater	19mm (¾ in)	283mm ²

Note – Equivalent areas of differently shaped drain openings are acceptable.

Total capacity must be calculated from the sum of the capacity of all cylinders housed in the same locker.

If the locker has two or more drains, their combined area of openings should be taken account of in assessing compliance.

Best practice
 We recommend all cylinder locker drains are not less than 19mm (¾ in) internal diameter or equivalent area.



7.4 Protecting LPG cylinders and components against damage

LPG cylinders and components can easily be damaged, both by day-to-day activities and by incidents like fire. Therefore, cylinder storage arrangements are important matters in minimising risk.

The preface on the nature of LPG highlights the potential dangers if cylinders are not kept upright. In general, LPG cylinders are designed to be stored and operated in an upright position with their cylinder valve uppermost.

If your cylinders move about they may damage their associated supply line, valves or regulators, causing leaks. Obviously the same risks apply if lockers aren't secure.

7.4.1/R REQUIREMENT

Are all cylinders secured and stored upright with the valve at the top?

Determine by moving the cylinders carefully the extent of any movement.

Check that all cylinders are secured to prevent potential damage to regulators or pipework.

Check the completeness and condition of support structures and fixings on transom-mounted LPG cylinder arrangements.

Check all cylinders are secured in the upright position with the valve uppermost.

The extent of any LPG cylinder movement must not cause any pulling of pipework or hose connections.

Cylinders must be secured so that the possibility of cylinders damaging low-pressure regulators, pipework or other LPG system components is minimised.

The support structures and fixings on transom-mounted LPG cylinder arrangements must be complete and free of signs of damage or deterioration.

Cylinders must be secured in the upright position with the valve uppermost.

7.4.2/R REQUIREMENT

Is the cylinder locker secure?

Apply light manual force to check that cylinder lockers are secure.

Cylinder lockers must be secured against unintended movement.

If you drop heavy objects such as mooring pins or windlasses on a cylinder valve, regulator or other components a leak could be the result.

7.4.3/R REQUIREMENT

Are LPG cylinders in a locker protected against falling objects?

Check for the presence of a lid or cover on all top-opening cylinder lockers.

If not present, check that the cylinders, regulators and associated equipment are otherwise protected.

Top-opening LPG cylinder lockers must either have a lid or cover. If not, cylinders, and other LPG system components must be otherwise protected against falling objects.

Owners using gas lockers casually to store loose objects or for additional purposes e.g. storing batteries run the risk of causing sparks, and/or blocking the locker drain (see Checklist Item 7.3.3).

7.4.4/R REQUIREMENT

Is the cylinder locker clear of any items that could damage the LPG equipment or ignite leaked LPG?

Check the contents of all cylinder lockers.

Cylinder lockers must not contain loose sharp or heavy items such as anchors or mooring pins that could damage the cylinders or other LPG system components.

Cylinder lockers must not contain any item that could ignite leaked LPG.

Note – sources of ignition include open-flame or spark-inducing equipment. Solenoid LPG system shut-off valves of suitable proprietary manufacture are **not** presumed to be a source of ignition.

LPG cylinders overheating in a fire will place people and property in the vicinity of the boat at extreme risk.

7.4.5/R REQUIREMENT

Is the cylinder locker constructed of material of the required thickness?

Determine the construction material of the cylinder lockers and estimate the thickness of the cylinder lockers.

Cylinder lockers must be constructed of materials that are either

- the same material and thickness of the surrounding hull structure; or,
- metal of minimum thickness of approximately 1mm; or,
- FRP of minimum thickness of approximately 5mm (¼ in) thickness.

Note – a combination of wooden cylinder-lockers lined with FRP of a lesser thickness than 5mm (¼ in) may be estimated as equivalent.

7.5 Cylinder locker opening

If cylinder lockers are in high-risk areas and they leak near sources of ignition, this could potentially cause a fire or explosion.

7.5.1/R REQUIREMENT

Are all openings to cylinder lockers outside of any engine, battery, or electrical equipment space?

Check the location of any opening of any cylinder locker.

Cylinder lockers must not open into engine, battery, or electrical equipment spaces.

Information

When choosing a solenoid-controlled shut-off valve, seek the supplier's assurance as to its suitability for use with LPG.



7.6 LPG system shut-off valves

In the event of a gas leak or fire breaking out, it is essential that the LPG supply can be quickly and easily shut off.

7.6.1/R REQUIREMENT

Are all LPG system shut-off valves, or their means of operation, in a readily accessible position?

Identify all valves used for the LPG system shut-off facility and check the accessibility of valves or their means of operation.

LPG system shut-off valves, or their means of operation, must be installed in a readily accessible position.

Notes – LPG system shut-off valves may be cylinder valves.

Systems with clip-on regulators do not require an additional system shut-off valve.

Best practice

Have your readily accessible shut-off valve, outside the accommodation space and as close to the LPG cylinders as possible.

b

7.6.2/R REQUIREMENT

Are the locations of all LPG system shut-off valves, or their means of operation, in open view or their locations clearly marked?

Identify the locations of the valves used for the LPG system shut-off facility. Where LPG system shut-off valve(s), or the means to operate them, are not in open view with all removable lids, deck boards, curtains, doors, etc in place, check for the presence of marking in open view indicating the location.

LPG system shut-off valves, or the means to operate them, must:

- be in open view with all removable lids, deck boards, curtains, doors, etc in place; or,
- have their locations clearly marked in open view.

7.7 High-pressure LPG system components

Location

All LPG fittings and components between the cylinder and the input side of the gas regulator (which is there to reduce and control the output pressure of the bottled gas to a pressure suitable for the appliances) are classed as the 'high-pressure' side of the LPG system.

Damage here could cause a very significant amount of LPG to escape rapidly before the cylinder shut-off valve can be closed. Protection against an influx of gas into the boat interior is therefore crucial.

7.7.1/R REQUIREMENT

Are all high-pressure LPG system components either inside a cylinder locker or in an open location?

Check the location of all high-pressure LPG system components.
Apply the checks at 7.1.1.

All high-pressure components must be installed in accordance with the requirements of Checklist Item 7.1.1.

Best practice

When working efficiently, a non-return valve will prevent a hazard when one cylinder is disconnected. However, early failure of these non-return valves has been reported so we recommend that they are checked regularly and that you renew a valve on any sign of failure.

b

Where two or more cylinders are connected on the high-pressure side e.g. via a wall block, manual or automatic changeover device, there is a risk of LPG escaping at high-pressure when one cylinder is disconnected.

7.7.2/R REQUIREMENT

Where two or more cylinders are connected on the high-pressure side, does each connection have a non-return valve fitted?

Identify the presence of cylinders connected on the high-pressure side. If present, check for a non-return valve fitted in each high-pressure connection.

Two or more cylinders connected on the high-pressure side must be protected by a non-return valve fitted in each connection.

Note – It may not always be obvious whether a non-return valve is fitted. Most modern wall blocks and high-pressure pigtails incorporate them. If you have any doubts, please ask a suitably competent person to advise you.

Automatic Changeover Device

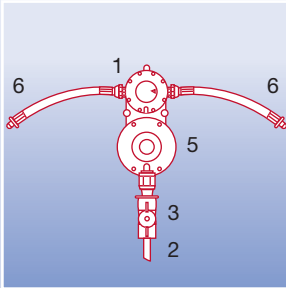

- 1 Automatic Valve
- 2 Low-pressure Gas Supply to Appliances
- 3 Main Shut-off Valve

Manual Changeover Device

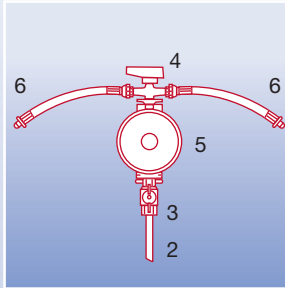

- 4 Manually Operated Valve
- 5 Gas Regulator

Wall Block

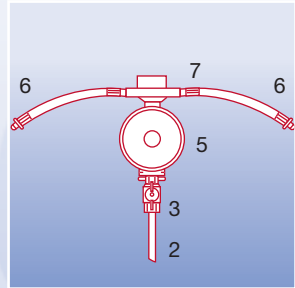

- 6 High-pressure Pigtails (Hose) to Cylinders
- 7 No Change-over Device

Best practice

Regulators have a finite life and it is generally recommended that they are replaced at least at 10-year intervals.



If a high-pressure LPG hose ruptures or becomes disconnected, your boat could be flooded with LPG regardless of its location.

7.7.3/R REQUIREMENT

Are all hoses on the high-pressure side of pre-assembled lengths not exceeding 1m (39 in) and to the correct specification?

Identify the presence of hose on the high-pressure side.

Check the type of hose end fittings.

Measure the length of hose.

Check the hose markings.

All LPG hoses on the high-pressure side:

- must consist of pre-assembled lengths of hose of proprietary manufacture; **and**,
- must not exceed 1m (39 in) in length; **and**,
- must be marked to BS 3212 type 2 or equivalent.

Note – Hoses marked to BS EN 1763 class 3 or 4 are acceptable.

Deterioration or damage to high-pressure components poses a high risk.

7.7.4/R REQUIREMENT

Are all high-pressure LPG system components secure and in good condition?

Check the condition of all regulators and associated high-pressure equipment and hoses and hose connections.

Check fixings for signs of damage or deterioration or missing components.

All high-pressure components, including regulators and associated equipment, hoses and hose connections, must be secure and free from signs of damage or deterioration.

Hose must be free of leaks, flaws, brittleness, cracking, abrasion, kinking, 'soft' spots, or joins.

Fixings must be free of signs of damage or deterioration or missing components.

In the same way, components can be damaged too easily, resulting in gas escape, when cylinders are being changed. It is also important to protect any vent holes in the regulator from water, dust and other debris.

7.7.5/R REQUIREMENT

Are regulators mounted directly on the cylinder(s) or located to prevent damage, including blocking of vent holes?

Check the location of regulators not mounted directly on cylinders.

Check that the vent holes of high-pressure stage components are protected from the ingress of debris or water.

Regulators not mounted directly on cylinders must be located in a position where they are not exposed to possible damage when changing cylinders.

The vent holes of high-pressure stage components must be protected from the ingress of debris or water.

Your LPG appliances operate within a certain pressure range. Above this level, the flame on an appliance may roar and lift off, which could ignite nearby fuel or vapour.

Below this range, an appliance burner may go out, allowing gas to leak into your boat.

7.7.6/R REQUIREMENT

Is the installation free of manually-adjustable regulators?

Check for the presence of any manually-adjustable regulators.

LPG regulators must not be of the manually-adjustable type.

Notes – Manually-adjustable regulators are acceptable for steam boiler or blowlamp engine-start LPG supply systems.

Regulators able to be adjusted upon removal of a ‘tools-to-remove’ dust cap are acceptable.

7.8 LPG metal pipework and connections

'Pipework' always refers to rigid supply lines; the section on flexible hose follows at 7.9. Although you will not be required to expose all the pipework for the BSS examination, it is important that all parts of the gas system installation pipework on your boat can be accessed for routine checking, service and replacement. Such routine inspection of the parts of the LPG system that are not readily visible is crucial, as damage or deterioration hidden from everyday view is by its nature a serious risk.

Hence, there are parts of the system that the BSS examiner will have to examine before he or she can issue a certificate. We recommend you plan for a successful examination, by reading this section carefully and making sure that all the required components can be examined.

Best practice

We recommend that pipework should be suitable for use with LPG in a marine environment.

To avoid vibration damage and early deterioration, we recommend that the fixings are not spaced more than 500mm (20 in) apart.

b

Movement and vibration can cause pipes to fracture and connections to loosen. If this happens to your system, the risk of gas escaping and building up in the interior of your craft is great.

7.8.1/R REQUIREMENT

Is the LPG pipework made of a suitable material, adequately secured and free from damage?

Visually check type of material for all LPG pipework that can be seen.
Apply light manual force to check security of LPG pipes that can be reached.

Check condition of all LPG pipes that can be seen or reached.

LPG pipework must be made of either seamless copper tube, or stainless steel tube, or copper nickel alloy.

LPG pipes must not move under light manual force.

LPG pipes must be free of kinks, restrictions, abrasion damage or other deterioration.

Notes – A little movement at the final connection to an appliance is acceptable.

Adhesive directly applied to the pipe is not acceptable as a fixing method.

Pay particular attention to the potential for abrasion damage on pipes passing through bulkheads.

Pipework passing through bulkheads, especially metallic ones, are at high risk of damage from abrasion. (See illustration Pg 25)

7.8.2/R REQUIREMENT

Is the LPG pipe protected where it passes through metal bulkheads or decks?

Check the protection of LPG pipes passing through metallic bulkheads or decks that can be seen or reached.

LPG pipes passing through metallic bulkheads or decks must be protected by the use of sleeves, grommets, or bulkhead fittings.

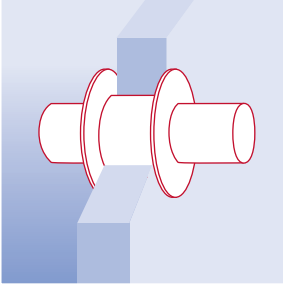

The pipe is passing through a bulkhead and the grommet supports it and protects against rubbing damage.
7.8.2

Joints are always higher-risk areas for potential leaks. If they are inaccessible, you cannot check their soundness and appropriateness. Inappropriate joints, can cause a gas escape, especially under conditions of stress.

7.8.3/R REQUIREMENT

Are all LPG pipe joints accessible for inspection and of the correct type?

Check the accessibility and type of all pipe joints.

All LPG pipe joints must be accessible for inspection.

All LPG pipe joints must be compression fittings on copper pipework or compression or screwed fittings on copper alloy or stainless steel pipework.

Notes – Where joints are inaccessible for inspection and their type is 'not verifiable', they are considered as non-compliant until their type is verified as acceptable.

Inspection panels to allow access to joints are considered compliant.

Best practice

Pipes that enter joints at abnormal angles can make a weak connection that may leak over time. It is best to have joints at a point where stress is minimal.

b

Stress and weakness in pipes has a number of sources, but all can be managed.

7.8.4/R REQUIREMENT

Are all LPG pipe joints secure, in good condition and competently made?

Measure the distance fixing clips are attached from all joint connections.

Apply light manual force to check security of each joint.

Check condition and completeness of fixings and joints.

Check all joints for the presence of unnecessary components.

All LPG pipe joints:

- must have fixing clips attached no more than 150mm (6 in) from each joint connection and must not move under light manual force; **and**,
- must have fixings that are free of signs of damage or deterioration or missing components; **and**,
- must be free of any signs of missing components, cracks or other signs of damage or deterioration; **and**,
- must be made with a minimum number of individual components.

Notes – Adhesive directly applied to the pipe joints is not acceptable as a fixing method.

Fixings are required on **all** sides of joints.

Where joints are inaccessible for inspection and their condition is 'not verifiable', they are considered as non-compliant until their condition is verified as acceptable.

Joints, such as reducing joints, are not expected to be made up of more than two individual components.

It is very easy for disused spurs or runs to be a source of gas escapes through poor capping, poor maintenance, damage or casual usage of taps, for example.

7.8.5/R REQUIREMENT

Are all unused appliance spurs properly capped or plugged?

Identify any unused appliance spurs and check they are closed with a 'tools-to-remove' proprietary plug or cap.

All unused appliance spurs must be closed with a 'tools-to-remove' proprietary plug or cap.

A gas escape into a petrol engine compartment or electrical equipment space, with the potential for a mix of fuels combining with multiple sources of ignition, which would create a serious risk of fire or explosion.

7.8.6/R REQUIREMENT

Are all LPG pipes running through petrol engine spaces or electrical equipment spaces jointless and in a gas-proof conduit?

Check for any LPG pipes running through petrol engine or electrical equipment spaces.

LPG pipes run through petrol engine spaces or electrical equipment spaces:

- must be jointless **and** in gas-proof conduit; which also,
- must be jointless with its ends outside the affected space; **and**,
- the conduit must be complete and free of signs of damage or deterioration.

Best practice

We recommend that unused spurs be plugged or capped at the 'T' joint on the supply line.

We recommend following industry best practice and keep the pipework as high as possible to help protect it from mechanical damage and allow you to smell a leak more easily if one occurs.

This advice also applies to the potential for water damage in the bilges, wherever possible, try to keep the pipework in the dry.

b

The effect of heat on pipework can cause it to expand and contract, which can lead to hardening of the pipework or loosening of its joints, which in turn could allow gas to escape.

7.8.7/R REQUIREMENT

Is the LPG pipe at least 75mm (3 in) from exhaust system and flue components?

Measure the distance that any LPG pipes are from exhaust system and flue components.

LPG pipes must be at least 75mm (3 in) from exhaust system and flue components.

Best practice

We recommend having 100mm (4 in) as the minimum gap between LPG pipe and exhaust or flue components.

b

7.9 LPG hoses and hose connections

As all flexible gas hose has a limited life, it is important to minimise the amount that is used on your boat. Please try and use the minimum practicable length.

Flexible hose, unsuitable for use with LPG will rapidly deteriorate and fail.

7.9.1/R REQUIREMENT

Are all LPG hoses on the low-pressure side accessible for inspection, of the correct material and in good condition?

Check the accessibility of all LPG hoses.

Check the markings of all LPG hoses.

Check the condition of hoses.

All LPG hoses must be accessible for inspection along their entire length.

All LPG hoses must be marked to BS 3212 type 2 or equivalent.

Hoses must be free of leaks, flaws, brittleness, cracking, abrasion, kinking, 'soft' spots or joins.

Note – hoses marked to BS EN 1763 class 2, 3 or 4 are acceptable.

At the time of inspection, hoses that are not accessible along their entire length are 'not verifiable', and will be considered as non-compliant until their general condition has been verified as meeting the requirement.

Pre-made flexible hose connections conforming to BS 669 may be used for cooker connections. Such hose connections usually have a red stripe running along the length of the hose and must terminate with self-closing bayonet connections. The portable appliance connection checks at 7.10 also apply.

Best practice

To prevent damage from abrasion and deterioration, we strongly recommend you follow industry best practice and ensure that any flexible hoses are installed without stress or tight radius turns on your craft.

b

Abrasion can quickly weaken the flexible hose to a point where it will leak.

7.9.2/R REQUIREMENT

Is all LPG hose protected against damage where it passes through bulkheads, decks or partitions?

Check the protection for LPG hoses passing through bulkheads, decks or partitions.

LPG hose passing through bulkheads, decks or partitions must be protected by the use of sleeves or grommets.

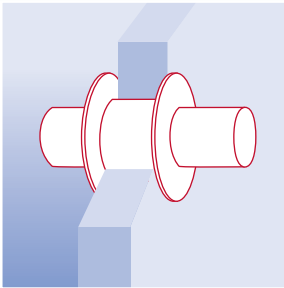

The hose is passing through a bulkhead and the grommet supports it and protects against rubbing damage.
7.9.2

Extreme heat will very quickly weaken LPG hose and long-term exposure to moderate heat will cause weaknesses in the hose walls.

7.9.3/R REQUIREMENT

Is all LPG hose at least 75mm (3 in) from exhaust system and flue components?

Measure the distance that any LPG hoses are from exhaust system and flue components.

LPG hoses must be at least 75mm (3 in) from exhaust system and flue components.

b**Best practice**

We recommend checking that any LPG hose is kept away from hot surfaces where temperatures may reach 50°C (122°F) or above such as

- Gas fridge flues
- Stoves
- Cookers
- Diesel heater exhausts.

Flexible hose can be used to connect the installation pipework to a gimbaled cooking appliance to allow for the movement. Other appliances such as your cooker or refrigerator can be connected by hose for ease of installation, cleaning or servicing.

Unnecessarily long lengths of flexible hose will introduce unreasonable risks.

7.9.4/R REQUIREMENT

Are all LPG hoses connecting appliances to supply pipework a maximum of 1m (39 in) in length?

Measure the length of any LPG hoses used to connect appliances to supply pipework.

LPG hoses used to connect appliances to supply pipework must not exceed 1m (39 in) in length.

The nature of hose, its deterioration with age, its vulnerability to heat and to damage, means that the risks associated with its use and the need for its regular checking and maintenance are all important.

7.9.5/R REQUIREMENT

Are all LPG hose connections accessible for inspection, of the correct type, secure and in good condition?

Check the accessibility of all hose connections.

Check types of all LPG hose connections.

Check the type, condition, and completeness of all hose connections.

Pull using light manual force to check security of all hose connections.

All LPG hose connections:

- must be accessible for inspection; **and**,
- must be part of pre-assembled lengths of hose of proprietary manufacture (high- and low-pressure applications); or use suitable nozzles secured by crimped or worm-drive clips (low-pressure applications only); **and**,
- must not be made using hose clamps fixed by spring tension; **and**,
- must be free of any missing components, cracks, burrs or rough edges or signs of other damage or deterioration; **and**,
- must not be so narrow as to cut into the hose; **and**,
- where made with crimped or worm-drive clamps, the clamps must be suitably sized, that is, not so oversized that the band forms an elliptical shape, or so undersized that inadequate compression is achieved; **and**,
- be appropriately tight, that is, not so loose that the connection can be pulled forward or back under light manual force nor so tight that the hose is excessively pinched.

Notes – Hose connections that are not accessible for inspection are ‘not verifiable’, and will be considered as non-compliant until their type, security and condition have been verified as meeting the requirement.

Inspection panels to allow access to joints are considered compliant.

Best practice

We recommend the use of hose clamps of approximately 8mm ($\frac{5}{16}$ in) width.

b

'All-hose' supply system

We cannot recommend using 'all-hose' systems since hose is known to permeate gas through its walls and it is not highly resistant to mechanical damage. LPG hose has minimal fire resistance. It deteriorates with age, with exposure to sunlight and exposure to the elements. If you are considering an all-hose system for new purchase or replacement, you are cautioned to consider these issues very carefully.

BS EN ISO 10239:2000 does recognise continuous 'all-hose' LPG supply-lines, however the UK National Annex also makes the following points: 'In line with the previous requirements in BS 5482-3, it is recommended that any application of LPG hose should be of minimum practical length. The installation should allow for regular inspection, at least annually, and for replacement if any deterioration is found.'

The risk of deterioration or damage to an all-hose system is much greater compared to that of pipework systems.

7.9.6/R REQUIREMENT

Do 'all-hose' systems comply fully with ISO 10239?

Check that 'all-hose' systems are fully compliant with ISO 10239.

'All hose' systems must fully comply with ISO 10239 as follows:

- each length of hose must be routed from within the cylinder locker or housing directly to the individual appliance or appliance isolation valve; **and**,
- hoses must have permanently attached end fittings, such as swaged sleeve or sleeve and threaded insert; **and**,
- hoses must not be routed through an engine compartment; **and**,
- hoses must be accessible for inspection over their entire length and connections must be readily accessible; **and**,
- hose connections must be stress free, i.e. not subjected to tension or kinking under any conditions of use; **and**,
- hoses must be supported at least at 1m (39 in) intervals.

Notes – ‘All-hose’ systems are those not using rigid pipework and will generally be found on imported boats, CE marked to the RCD, where the builder has chosen to apply ISO 10239.

For multi-appliance systems to ISO 10239, we anticipate a manifold arrangement within the cylinder locker or housing.

All of the hose and hose connection **condition** checks at 7.9.1 and 7.9.5 also apply.

Single cooking appliances connected by hose of no more than 1m (39in) in length directly to a regulator are acceptable and need not be assessed against this check.

7.10 Portable appliance connections

A portable appliance for the purposes of the Scheme is one designed to be portable and connected to the LPG supply system by flexible hose.

As its name suggests, a portable appliance will be connected and disconnected regularly. This introduces extra hazards in terms of the isolation of the appliance, the reliability of the supply line and the potential for weak points. These matters are considered in this section.

7.10.1/R REQUIREMENT

Are all portable appliance connections provided with an isolation valve?

Identify all portable appliance connections and check for the presence of an isolation valve.

Apply the checks at 7.11.2 and 7.11.3.

All portable appliance connections must be fitted with an isolation valve.

Where appliances have been permanently removed or temporarily removed for servicing, there is increasing potential for gas leaks.

7.10.2/R REQUIREMENT

Are portable appliance hoses connected with bayonet, plug or screwed fittings, complete and in good condition?

Identify the type of appliance hose connection to the isolation valve.

Check all connections for completeness and condition.

All hose connections to the isolation valves of portable appliances must be made with a bayonet, plug-in or screwed fitting.

All bayonet, plug-in or screwed fittings must not be missing any components and must be free of corrosion, signs of damage or deterioration.

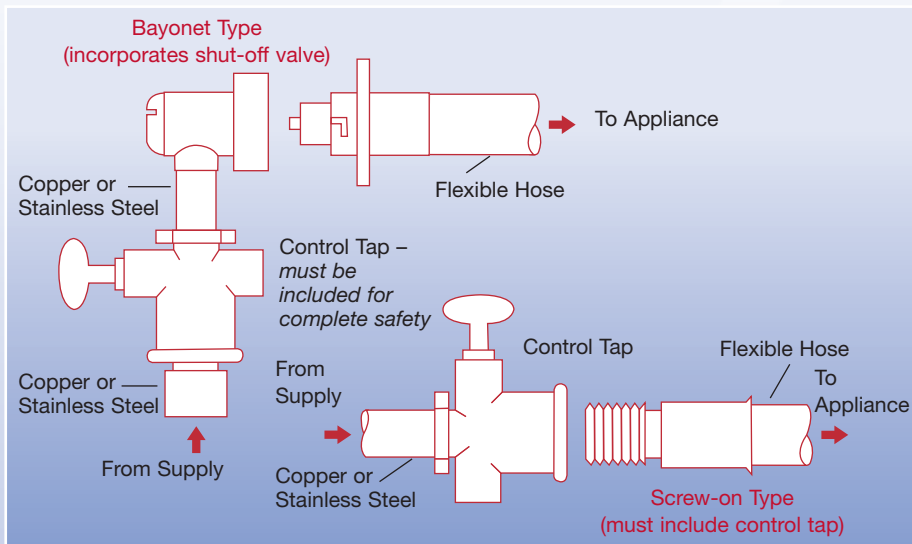

Unused threaded connections must be backed up with a secondary means of shutting off the gas supply.

7.10.3/R REQUIREMENT

Are all unused screwed portable appliance connection points properly capped or plugged?

Identify any unused screwed appliance connection points and determine how they are plugged or capped.

All unused screwed appliance connection points must be closed with a 'tools-to-remove' proprietary plug or cap.

7.11 Appliance isolation valves

These valves allow the individual appliance, to be isolated or made safe, as well as providing a safe shut-off to disconnect for replacement or maintenance purposes.

Flexible hose fails over time so you will need a feature that allows the connection to be isolated safely from the main supply system if it cracks, leaks or otherwise needs replacing.

7.11.1/R REQUIREMENT

Can all appliance supply hoses be isolated through individual shut-off valves?

Identify every appliance connected by a flexible hose and confirm the presence of an individual shut-off valve at the connection to the supply line.

Appliances connected by a flexible hose must be provided with an individual shut-off valve at the connection to the supply line.

Notes – For an installation with a single appliance connected by a hose, the cylinder valve may be classed as the appliance isolation valve.

Ease of access takes precedence over the requirement for the valve to be located at the connection to the supply line.

Hob/oven arrangements may be deemed one appliance for the purposes of this check.

The nature of LPG means that the use of unsuitable valves can allow gas to leak.

7.11.2/R REQUIREMENT

Are appliance isolation valves of the correct type?

Identify the type of all appliance isolation valves.

Any tapered plug-type valves used as isolation valves must be spring loaded.

Needle-type valves used as isolation valves are not permitted.

Appliance isolation valves at floor level must either be of the drop-fan or loose-key type or of a type that cannot be operated inadvertently.

Note – If the spring on a spring-loaded tapered plug valve is found not to be free to operate without interference because of its close fitting against the surface behind it, then the valve is not to be considered as being spring-loaded.

Not closing the right valve to isolate an appliance can lead to a gas escape.

It may also be important for the isolation valves to be quickly identified, and closed by anyone coming onto the boat, but the main shut-off valve is the key one to make the whole system safe.

7.11.3/R REQUIREMENT

Are appliance isolation valves, or the means of operating them, readily accessible?

Check the accessibility of all isolation valves, or the means of operating them.

Appliance isolation valves, or the means of operating the valves, must be readily accessible.

Note – Isolation valves located behind free-standing LPG cookers that are restrained from tilting, are compliant if the restraint can be unfastened without the use of tools.

Best practice

We recommend using the main shut-off valve as the primary emergency shut-off.

b**Best practice**

We recommend all appliances are protected by an appliance isolation valve.

We recommend the industry best practice that valves which are not immediately adjacent to appliances, or otherwise in open view, have their location, and the identity of which appliance they serve, clearly marked.

For ease of use and maintenance we recommend having these valves readily accessible, the operating instructions marked on or close by. If the valves operate by rotation, it is industry best practice that they close by turning clockwise.

b

7.12 Testing for LPG system tightness

It cannot be assumed that a boat's LPG system is leak-free without checking. This section covers the requirement for a means to test and the available options for testing. (see illustrations on Pg 38).

7.12.1/R REQUIREMENT

Is there a LPG test point in the system, or a bubble tester in the cylinder locker or housing?

Check for the presence and location and accessibility of a means to determine the LPG system tightness.

All LPG systems must be fitted with one of the following means to determine gas tightness:

- a readily accessible proprietary test point on an appliance; or,
- a readily accessible proprietary test point fitted in the pipework; or,
- a bubble tester installed in a cylinder locker or cylinder housing.

7.12.2/R REQUIREMENT

Is the LPG system free of leaks as defined in the tightness test?

The regular verification that the LPG system is leak-free is important. The use of suitable proprietary bubble testers is strongly recommended, as it allow boaters to easily, routinely and safely test for gas leaks.

Alternatively have a competent person use the built-in test point(s) as detailed in Appendix C of the Examination Checking Procedures, which is available on www.boatsafetyscheme.com or by post or email from the BSS Office.

Vessels used for certain purposes, e.g. as a main residence, may be governed by UK law, thus restricting this latter method to CORGI-registered fitters.

All LPG systems must be free of leaks when tested in accordance with the appropriate tightness test procedure.

Notes – If for any reason the tightness test can not be completed when required, the soundness of the system is ‘not verified’ and it is considered as non-compliant until it can be verified. The reason for non-completion must be recorded.

A leak in the system is classified as ‘immediately dangerous’. A Warning Notice will be issued and the navigation or harbour authority will be informed.

Information

There is more information on the tests that check the tightness of a gas system in PD 5482-3.

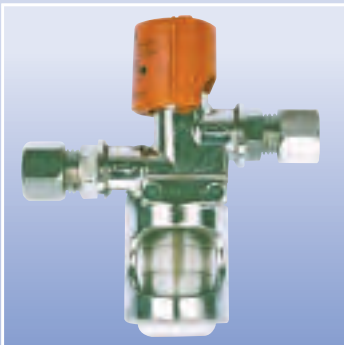

Bubble tester - a highly recommended installation

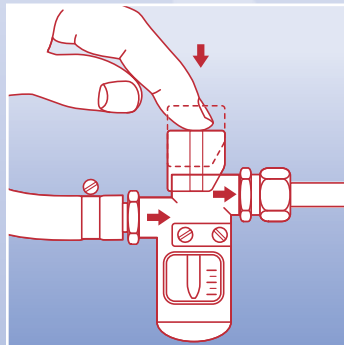

Follow manufacturer's operating instructions.

8

Cooking, heating, refrigerating and lighting appliances

The Boat Safety Scheme Essential Guide



For more technical information

The requirements in this chapter have been informed by, and may refer to, the following technical references, codes and regulations. If you are building, fitting-out or making substantial changes to a vessel, we strongly recommend you refer to, and take account of, the codes and standards below:

- **BS 5258-11:1980 Safety of domestic gas appliances. Flueless catalytic combustion heaters (3rd family gases) (superseded, withdrawn)**
- **BS EN 449:2002 Specification for dedicated liquefied petroleum gas appliances. Domestic flueless space heaters (including diffusive catalytic combustion heaters)**
- **BS EN 9094-2:2002 'Small craft – Fire protection. Part 2: Craft with a hull length of over 15m'**
- **BS EN ISO 10239 'Small craft – liquefied petroleum gas (LPG) systems'**
- **BS EN ISO 14895 'Liquid fuelled galley stoves'**
- **PD 5482-3:2005 'Code of practice for domestic butane and propane gas-burning installations – Part 3: Installations in boats, yachts and other vessels'**
- **Statutory Instrument 1998 No. 2451 The Gas Safety (Installation and Use) Regulations 1998' (www.opsi.gov.uk/si/si1998/19982451.htm)**
- **Calor Gas: 'LPG (Bottled Gas) for Marine Use'**



BSS Essential Guide

This chapter considers the means to minimise the risk of fire and explosion caused by fuel leaking from appliances or by overheating surfaces and materials. Also highlighted, are the potential risks from ignition sources, such as pilot lights.

This chapter covers the capacity of an appliance to shut down automatically if its flame goes out and it examines what is a 'satisfactory flame picture' and why one is necessary to stay safe. The need to turn off appliances with naked flames and disable automatic ignition systems before taking on fuel is covered here too.

Inadequate ventilation has been the cause of avoidable and tragic accidents on boats. It is a cause, but not the only one, of incomplete or inefficient combustion of gas, solid or liquid fuels that can lead to a lethal build-up of carbon monoxide. Whether the cause of this toxic gas is poor burning, blocked flues or leaking exhausts, it can be prevented by having appliances properly installed and maintained both competently and routinely.

Boats obliged to meet BSS requirements must comply with the following:

- 25** All appliances must be designed, installed and maintained in a way that minimises the risks of explosion or of fire starting and spreading.

- 26** All liquid-fuelled appliances must have an emergency shut-off valve located at a safe distance from the appliance.

- 27** a) **LPG and liquid-fuel burning appliances installed from 3 January 2000**

All burners and pilot lights shall be fitted with a device that automatically shuts off the fuel supply if the burner flame fails.

- b) **LPG and liquid-fuel burning appliances installed before 3 January 2000**
-

Burners on catalytic appliances, appliances with continuously-burning flames and pilot light burners shall be fitted with a device that automatically shuts off the fuel supply if the burner flame fails.

- 28** All appliance flues must be designed, installed and maintained in a way that minimises the risk of fire.
-
- 29** All fuel and power supply systems for appliances must meet these general requirements where relevant.
-

There is good advice on keeping people safe from carbon monoxide on your boat in our leaflet 'Avoiding The Silent Threat – Carbon Monoxide'.



Carbon monoxide - the silent threat

Your safety, that of your crew and that of visitors to the boat is in your hands, but we will offer you some information and advice, which may help you with that responsibility. To that end, we draw your attention the risks of carbon monoxide poisoning and we will help you identify possible hazards caused by installations burning carbon-based fuels such as LPG, coal, wood, petrol and diesel.

The production of carbon monoxide even at low rates over a period of time can lead to dangerous accumulations of this toxic gas in enclosed spaces. For this reason, we urge you to use only appliances that are serviceable, in good condition and suitable for use in a boat.

Furthermore, for greater safety we recommend that you choose room-sealed appliances, whenever possible. There is a growing recognition of the risks associated with the use of non-room sealed gas appliances when used in confined spaces such as boats. This is very important with appliances that operate for extended periods and during the night. It is vital that you have them maintained regularly by competent persons and, of course, always in accordance with the manufacturer's recommendations.

8.1 Appliance fuel and power supply

The safe installation and condition of the appliance must be supported by a safe fuel or power supply.

8.1.1/R REQUIREMENT

Does the fuel or power supply to an appliance meet the applicable BSS requirements?

For each appliance, identify the type of fuel or power supply arrangements and apply the checks of the relevant chapter of the BSS General Requirements.

The fuel or power supply arrangements for all installed appliances must meet the applicable BSS General Requirements.

Note – Concerning diesel, paraffin, electric, or LPG installed appliances, apply the requirements in Chapters 2, 3, and 7 respectively, as appropriate.

The ability to shut off fuel supplies in the event of an emergency can prevent a fire from starting or from getting worse. The means to shut off that supply must be safely, easily and quickly accessible in an emergency.

8.1.2/R REQUIREMENT

Are all liquid-fuelled appliances fitted with shut-off valves, and are the valves or their means of operation in a readily accessible and safe position?

Identify all fuel supplies to liquid-fuelled appliances and check for the presence of valves or cocks.

Check the position and accessibility of the valves or cocks, or their means of operation.

Liquid-fuelled appliances must be provided with a valve or cock to shut off the fuel supply.

All shut-off valves or cocks, or their means of operation, must be installed in a readily accessible position.

All shut-off valves or cocks, or their means of operation, must be installed within reach of the appliance but not in a position that requires the user to reach over or around the appliance to operate them.

Notes – This check does not cancel out the fuel tank shut-off requirements at Checklist Item 2.13.1, which must be met.

The valve or cock should normally be situated in the same compartment as the appliance. However, there may be installations where it is not physically possible or safe to do so. For example: where the appliance is installed on a bulkhead between compartments; or, if there is less than approximately 1m (39 in) of fuel pipe in the same compartment. In these cases it is acceptable for the valve or cock to be installed at the nearest practicable point.

Automatic fire valves of a suitable proprietary type are an acceptable alternative to manually operated valves or cocks. Where fire valves are installed, fitting them immediately adjacent to the appliance will help ensure their usefulness in case of an appliance fire.

Appliances fitted with electrical fuel-supply pumps that shut off the fuel supply when the pump is not in use, are an acceptable alternative to manually-operated valves or cocks.

8.2 LPG or paraffin refrigerators on vessels with petrol propulsion engines

There have been numerous explosions resulting from the use of gas refrigerators with naked flames on petrol-powered boats.

The low-level permanent flame of a pilot light or burner could light any stray petrol or petrol vapour.

8.2.1/R REQUIREMENT

Where the vessel has a petrol propulsion engine, is the burner of a LPG or paraffin refrigerator room-sealed, or completely enclosed?

Identify the presence of a non-room sealed LPG or paraffin refrigerator in a vessel with a petrol propulsion engine.

If present, check that the burner is totally enclosed, or if necessary, have available a declaration from an equipment manufacturer or supplier that supports compliance.

The burners of LPG or paraffin refrigerators in vessels with petrol-propulsion engines, must be room-sealed or completely enclosed.

Notes – This check is limited to vessels with petrol propulsion engines, including outboard motors.

If the burner assembly is not visible, and its compliance is not supported by a declaration from the manufacturer or supplier, the fridge will be considered as non-compliant until its suitability can be verified.

Known room-sealed models include the Electrolux RB180, RB182, RM4213 LSC and RM6401 LSC models.

If a boat does not comply with this requirement, a warning notice will be issued and the navigation or harbour authority will be informed.

8.2.2/R REQUIREMENT

On vessels with petrol propulsion engines that have non-room sealed fridges with enclosed burners, is the combustion air drawn and exhausted through a suitable effective flame trap or piped to the appliance as required?

Identify the presence of a non-room sealed LPG or paraffin refrigerator with an enclosed burner in a vessel with a petrol propulsion engine.

If present, check the air intake and exhaust for the presence of a suitable flame trap.

If the combustion air is not drawn and exhausted through a suitable flame trap visually check how the air is piped to and exhausted from the appliance.

The air intakes and exhausts of non-room sealed LPG or paraffin refrigerators in petrol-engined vessels must pass through a flame trap, with a gauze of not less than 11 wires per linear cm (28 wires per inch) mesh.

If the combustion air is not drawn and exhausted through a suitable flame trap, the combustion air and exhaust must be piped to the appliance from either:

- outside the vessel; or,
- a point inside the vessel above the level of windows, other openings, or other means of ventilation in the accommodation space.

Notes – If the combustion air intake and/or the burner is not visible, and its compliance is not supported by a declaration from the manufacturer or supplier, the fridge will be considered as non-compliant until its suitability can be verified.

If a boat does not comply with this requirement, a warning notice will be issued and the navigation or harbour authority will be informed.

8.3 Installation of appliances in petrol-engine spaces

Special care must be taken with spaces where there could be petrol vapour. Petrol vapour mixed with air is highly explosive and there is a risk that it could be ignited by an appliance burner.

8.3.1/R REQUIREMENT

Are petrol-engine spaces free of LPG and/or liquid-fuelled appliances?

Check petrol-engine spaces for the presence of LPG and/or liquid-fuelled appliances.

LPG and/or liquid-fuelled appliances must not be installed in petrol-engine spaces.

Notes – In certain circumstances LPG and/or liquid-fuelled appliances may be located in petrol-engine spaces where they are installed in a separate vapour-tight compartment. If your boat has such an installation and you wish to claim compliance or equivalence, please contact the BSS Office.

The installation will not be compliant if the appliance is located outside of the engine space but the air intake to that appliance is located within the space.

Best practice

Some appliances are unsuited for use on boats e.g. where they generate too much heat in a confined space or where they are heavy and unstable. To prevent problems seek reassurance from the supplier that each appliance is suitable for use on your boat; that it is situated in sufficient space and that it is properly installed according to the manufacturer's instructions specifically for boats.

b

8.4 Protection against fire risks from appliance installations (including solid-fuel and liquid-fuelled appliances)

If surfaces or fabrics next to an appliance get overheated, there is a danger that they could catch fire.

For example enough heat from a solid-fuel stove can reach a tiled surround to cause burning in a timber framework underneath the tiled surface.

8.4.1/R REQUIREMENT

Are appliances and surrounding surfaces clear of signs of heat damage and leaking fuel?

Check all appliances and all their surrounding surfaces for signs of heat damage and leaking fuel.

Appliances and all their surrounding surfaces must not show signs of:

- scorching, blistering or discolouration; or,
- fuel leakage; or,
- smoke or soot deposits; or,
- heat damage or deterioration to appliance structure.

Note – This check applies to all fuel burning appliances.

8.4.2/R REQUIREMENT

Are all curtains, blinds and other textile materials near to appliances free of heat damage?

Check all curtains, blinds and other textile materials near appliances for signs of heat damage.

Curtains, blinds and other textile materials near all appliances must not show signs of heat damage such as scorching or burning.

Best practice

We highly recommend meeting the fire-proofing standards for surfaces adjacent to appliances set out in BS EN ISO 9094. Also, free-hanging curtains or other fabrics are best fitted well away from appliance burners. Supplementary information on these recommendations is available on www.boatsafetyscheme.com or by post or email from the BSS Office.

b

8.4.3/R REQUIREMENT

Are non-portable appliances properly secured against accidental or unintended movement?

Check for the presence and condition of securing systems on all non-portable appliances.

Where practicable, apply light manual force to check the security of all non-portable appliances.

Where a manual check is not practicable, such as with solid fuel and oil-fired stoves, check the condition of securing systems.

Non-portable appliances must be incapable of unintended movement in any direction.

Securing systems must be installed on all non-portable appliances and securing systems and their fixing points must be of suitable strength and must:

- show no signs of fractured mounting brackets;
- not have loose, missing or fractured bolts or nuts.

Notes – Appliances in gimbals may tilt, but the retaining mechanism must be secure.

Appliances connected to the fuel supply by hoses or electrical cables may be retained using fixed chains provided there is no possibility of strain on the hose and/or cable connections.

This check applies to liquid-fuelled, solid-fuel and LPG appliances only.

Information

Gas appliances can be connected with flexible hoses; read Chapter 7 of this Guide especially sections 7.9-7.10 for details.



8.5 Protection against fire risks from appliance flues and exhausts

Appliance flues carry very hot gases and can be the source of both conducted and radiated heat such that combustible materials nearby or brushing against these flues can begin to burn.

8.5.1/R REQUIREMENT

Are all vessel structures, equipment, and curtains, blinds and other textile materials near appliance flues free of signs of heat damage?

Check vessel structures, equipment, and curtains, blinds and other textile materials near all appliance flues and exhausts for signs of heat damage.

Vessel structures, equipment, and curtains, blinds and other textile materials near all appliance flues and exhausts must not show signs of heat damage such as scorching, blistering or discolouration.

Note – This applies to all fuel-burning appliances with flues or exhausts.

8.6 LPG catalytic heaters

Catalytic heaters are known to fail over time, so you need to be certain that the fuel supply will shut off if yours has a problem.

8.6.1/R REQUIREMENT

Is a LPG catalytic heater compliant with a suitable manufacturing standard?

Identify any LPG catalytic heaters and check compliance with the following aspects of BS 5258-11 or BS EN 449 by visual inspection:

For BS 5258-11 check:

- provision of a guard; **and**,
- three-position on-off tap; **and**,
- flexible tubing to BS 3212 type 2.

For BS EN 449 check:

- legible and durable marking of open, closed and any reduced-rate positions on control taps; **and**,
- clear marking of any special position of the control tap for ignition; **and**,
- provision of a fireguard.

LPG catalytic heating appliances must comply with the elements of:

- BS 5258-11; or,
- BS EN 449

as prescribed in the check.

8.7 Flame supervision/ failure devices (FSD/FFD)

This section covers the use of a safety feature that, depending on the date of installation and the type of appliance, is either a requirement, or a highly recommended feature even when it is not mandatory.

If the burner on any of your appliances goes out and the fuel continues to flow and is ignited this could start a fire or cause an explosion.

8.7.1/R REQUIREMENT**Are flame supervision devices fitted to all LPG and liquid-fuelled appliances that require them?**

Check all LPG and liquid-fuelled appliances for the presence of flame supervision devices.

For any LPG appliance not fitted with flame supervision device(s) seek to determine from the owner, or from available documentary evidence, the date the appliance was installed.

For any liquid-fuelled appliance not fitted with flame supervision device(s), seek to determine from the owner, or from available documentary evidence, whether the appliance manufacturer requires such a device to be fitted.

For LPG appliances:

All the burners and pilot lights of LPG appliances installed **on or after 3 January 2000** must be fitted with a device that automatically shuts off the LPG supply if the burner flame fails.

LPG appliances installed **before 3 January 2000** must be fitted with a device that automatically shuts off the LPG supply if the burner flame fails on:

- the burners on catalytic appliances; **and**,
- appliances with continuously-burning flames; **and**,
- pilot light burners.

For liquid-fuelled appliances:

Flame supervision devices must be fitted to all liquid-fuelled appliances where the appliance manufacturer requires such a device to be fitted.

Notes – If you are unsure of whether a particular liquid-fuelled appliance should be fitted with a flame failure device, or seeking clarification as to the suitability of such a device, you should contact the BSS Office.

Engine-start blowlamps and gas pokers are not required to have FSDs.

8.8 LPG appliance burner operation**Incorrect gas pressure at an appliance will result in ineffective combustion and unusual flame behaviour.**

If the pressure is too low, the burner flame on an appliance can go out. This can result in gas leaking into your boat and the risk of fire or explosion. If it's too high, the flame can lift-off the burner and extinguish.

If the combustion air supply is insufficient the burner may produce a yellow or sooty flame, which can be the source of carbon monoxide.

8.8.1/R REQUIREMENT

Are all LPG appliance burners in good condition and delivering a proper flame?

Light all LPG appliance burners and operate them at their maximum setting at the same time.

Compare the flame pictures at each burner to the 'burner flame trouble' illustrations below.

A satisfactory flame picture must be present at each LPG appliance burner when all burners in the system are operating at their maximum setting at the same time.

Note – Any appliances with 'hidden' burners will be ignited as part of this check at examination, but there is no requirement to see the burner flame picture.

In the event of a poor flame picture, shut down the LPG supply and have a competent person remedy the fault. If an examiner discovers such a fault he or she will issue a warning notice and may have to inform the navigation or harbour authority. In particular, if the regulator is operating outside of the lock-up tolerance, or is more than 10 years old, or is marked in imperial units, the BSS Warning Notice will include a note about the performance or age of the regulator as appropriate.

At the time of examination if any appliance burner cannot be lit it will be considered 'not verified' and the reason why noted. It is considered as non-compliant until such time as its good condition has been verified.

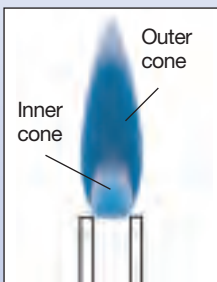

Gas and air in correct proportions

Good pattern

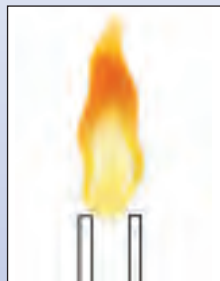

Too much gas,
too little air

Incomplete combustion
Sooty yellow flame



Too much air,
too little gas

Flame travels back
to injector

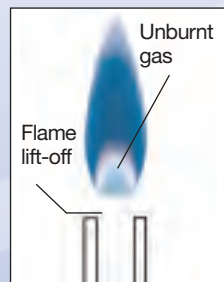

Pressure too high,
too much primary air

Flame lifts off

Best practice

Regulators have a finite life and it is generally recommended that they are replaced at least at 10-year intervals.

b

8.9 Ventilation

The responsibility for the safety of anybody onboard your boat lies with the owner or skipper. We advise strongly that boats have enough fixed ventilation to feed all the appliances on board that use LPG, coal, wood, oil or other carbon-based fuels.

Inadequate ventilation will starve the burners of vital oxygen resulting in poor burning and that can produce highly toxic carbon monoxide.

Room-sealed appliances have their own external air supply built into the flue ductwork, but other appliances take their combustion air supply directly from the cabin space.

The ventilation requirement can be calculated by using the formula from Annex B of PD 5482-3. It takes account of the number and type of appliances as well as the people on board.

Minimum effective area (mm²) = [2200xU]+[650xP]+[440xF]

U = total input rating (kW) for all appliances (including cookers) without flues

P = number of people for which the compartment is designed

F = input rating (kW) for all open or closed flue appliances

The input rating for your appliances can normally be found on the manufacturer's plate on the appliance and/or in the operating instructions.

The ventilation requirement needs to be split as equally as practicable between:

- high level (ideally cabin roof), and,
- low level.

Low-level venting can be achieved by letting in cold air from vents in doors and/or bulkheads, or by means of ducting from a higher level.

Careful examination must be made of each ventilator to check for the presence of anything that would reduce the clear air opening e.g. filter, insect screen. Such filters or screens must also be in a clean and serviceable condition as partial or complete blockage of the clear air openings could make the ventilator totally ineffective and your calculations inaccurate. Louvered doors are a common form of providing permanent ventilation and the effective area needs to be carefully measured.

8.9.1/A ADVICE

Is fixed ventilation in accordance with the relevant standard?

Calculate the fixed ventilation requirements in accordance with guidance immediately preceding this box.

Measure the effective area of fixed high- and low-level ventilation.

Confirm that the fixed ventilation area is divided as equally as practicable between high and low level.

Fixed ventilation accords with Annex B of PD 5482-3.

Notes – Ventilators that can be closed without the use of tools must not be included in the calculations except for seagoing boats with ventilator-closing devices.

Permanent and measurable gaps around doors and windows when the windows or doors are fully closed can be taken into account as part of the total fixed ventilation provision.

In the event of a shortfall, we recommend remedying the fault as soon as possible. If an examiner discovers a significant shortfall he or she will issue a warning notice. A significant shortfall is 50% of the calculated fixed ventilation requirement; or, any shortfall in the calculated requirement for continuous-burning appliances; or, the existence of no high- or no low-level ventilation.

Supplementary advice concerning ventilation can be found on www.boatsafetyscheme.com or can be sent by email or post from the BSS Office.

If your boat is used exclusively on inland waterways, we recommend strongly that the ventilators are fixed open. This is not always practical; for example with sea-going boats that experience severe weather and require ventilators to be closed for weather tightness. In this case a warning notice e.g. 'Warning – open ventilator(s) before use' fixed close by every appropriate appliance is recommended.

8.9.2/A ADVICE

Are warning notices displayed on sea-going boats with closable ventilators?

Identify seagoing boats with closable ventilators.

Check for the presence of, and the wording on, warning notices on or near to all non-room sealed fuel-burning appliances.

On all sea-going boats with closable ventilators a warning notice is displayed on or near all non-room sealed fuel-burning appliances.

The warning notice must read: 'WARNING – open ventilator(s) before use'.

Note – If your examiner records a fault is here, he or she may issue a warning notice.

8.10 Flues and draught diverters

Defective or inappropriate flues can cause a build-up of combustion by-products inside the cabin space, which may lead to a risk of carbon monoxide poisoning. This is an important safety issue and one where the responsibility rests with the boat owner.

With *non* room-sealed appliances

For your own safety, appliances recommended as needing a flue are:

- instantaneous water heaters, supplying a bath or shower
- instantaneous water heaters installed in confined spaces
- instantaneous water heaters which serve more than one hot water outlet
- solid fuel appliances
- any appliance which is fitted with a flue spigot.

With *room-sealed* appliances

Defective or inappropriate flue ductwork serving room-sealed appliances could cause an escape of products of combustion or carbon monoxide into the cabin space. Flue components, including ductwork and terminals on room-sealed appliances installed according to the manufacturer's instructions will minimise this risk. Some flues are fabricated from corrugated and relatively thin material that is susceptible to damage if it is not properly installed.

Open Flue System

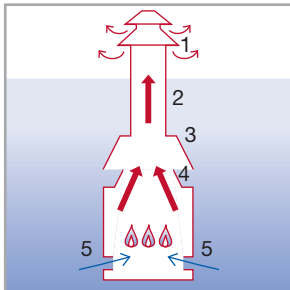

1 Terminal
2 Secondary Flue

Closed Flue System

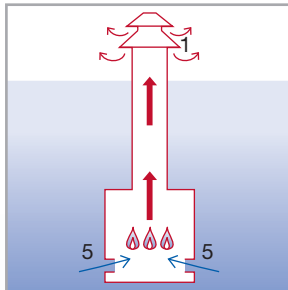

3 Down Draught Diverter
4 Primary Flue

Room-Sealed System

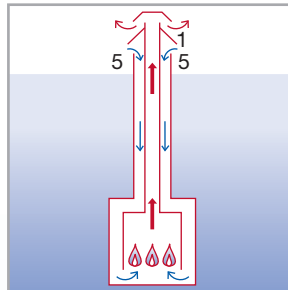

5 Air Inlet

8.10.1/A ADVICE

Are all appliances requiring a flue fitted with one?

Check that:

- a flue and draught diverter are fitted to all multi-point instantaneous water heaters and those single point instantaneous water heaters supplying a shower or bath; **and**,
- a flue is fitted to any appliance fitted with a flue spigot and any solid-fuel or oil burning appliance; **and**,
- flue components including air intake and flue ductwork and terminals are fitted to all room-sealed appliances; **and**,
- a flue does not serve more than one appliance.

A flue must be fitted to all appliances designed exclusively for use with one as prescribed in the check.

Flues must not serve more than one appliance.

Note – If an examiner discovers a fault he or she will issue a warning notice.

Advice about flue condition

The examiner must visually inspect flues, flue securing and flue terminals where these are readily accessible before offering you advice about any defects he or she may have found relating to:

- completeness
- obstruction
- signs of damage or flue gases escaping into cabin areas.

Carbon monoxide from appliances can enter the cabin space if there is no flue where one is required.

Flues deteriorate over time and can be easily damaged or blocked.**8.10.2/A ADVICE****Are all flues complete and in good condition?**

Check the condition of all flues and ductwork, flue terminals and flue joints and securing mechanisms that can be seen or reached.

All flues must be complete, properly fitted and maintained and must show no obvious signs of:

- obstruction or flue diameter restriction; or,
- crushed or blocked terminals; or,
- modifications to the flue not in accordance with the appliance manufacturer's recommendations; or,
- damage or deterioration; or,
- evidence of flue gases escaping into cabin areas (soot deposits, etc).

Notes – If an examiner discovers a fault here, he or she will issue a Warning Notice.

Examples of obvious unsuitable flue modifications include extensions to LPG fridge flues and tin cans used as flue terminals.

LPG and paraffin fridges in non-petrol-engined boats may be installed to open-vent into the boat's interior, but the use of a suitable proprietary flue is recommended. Any components added to the appliance's integral flue stack may place people aboard at risk and will be recorded as a hazardous fault at examination.

During the examination instantaneous water heater flue length and terminal suitability will be checked by the flue spillage test (8.10.4).

Flue terminals that can be enclosed by your boat's canopies may be a potential carbon monoxide hazard.**8.10.3/A ADVICE****Do all flues terminate directly to outside air?**

Check the location of all flue terminals.

Check for the presence of a canopy or canopy fixings where a flue terminates at any part of the vessel which could be enclosed by a canopy.

Flue terminals must be located outside the interior of the vessel and outside of any areas which may be enclosed by a canopy.

Note – If an examiner discovers a fault here, he or she will issue a warning notice.

8.10.4/A ADVICE

Are all open flues operating effectively?

In the event no fault is recorded at Checklist Item 8.10.3 in connection with the appliance, a BSS examination will include a flue spillage test on all appliances with open flues. Details are available on www.boatsafetyscheme.com or from the BSS Office by phone, post or email.

Open flues must ensure safe transfer of flue gases to the outside of the boat.

Note – A test will not be carried out if its outcome is likely to be affected by flue damage, obstruction or unsuitability determined at Checklist Item 8.10.2. Nor will a flue spillage test be carried out on fridges with open flues.

If an examiner discovers a fault here, he or she will issue a warning notice.

At examination, if for any reason the examiner cannot complete a flue spillage test, the report will note that this check is 'not verified' and the reason(s) why.

Information

The warning notice gives brief details of the problem(s) an examiner has identified. There is more information on warning notices in the Introduction to this Essential Guide, (see Pg 15).



9

Pollution reduction

The Boat Safety Scheme Essential Guide



For more technical information

The requirements in this chapter have been informed by, and may refer to, the following technical references, codes and regulations. If you are building, fitting-out or making substantial changes to a vessel, we strongly recommend you refer to, and take account of, the codes and standards below:

- **BS EN ISO 8099:2001 'Small Craft. Toilet waste retention systems'**



Pollution reduction

Our waterway environments are important to all boaters, visitors and the wider community. Good water quality is vital to the safety and enjoyment of people, animals and wildlife, in and around rivers, lakes and canals.

Pollution can harm a waterway's environment, cause health problems for people affected and, whilst pollution incidents are being controlled, restrict or stop people from navigating in the vicinity.

Most navigation authorities have duties to safeguard the environment.

These requirements address the potential for boats and their use to cause water pollution.

Boats obliged to meet BSS requirements must comply with the following:

- 30** Any leakage of oil from engine equipment must be contained and prevented from being avoidably discharged overboard.

- 31** Bilge pumping and toilet systems must be designed, installed and maintained in a way that minimises the risk of avoidable pollution.

There are more ways to protect the quality of navigable waters

The Green Blue is an environmental initiative specifically for boat users promoted by the Royal Yachting Association and the British Marine Federation. The Green Blue offers a lot of practical information about the environmental impacts of boating, and how to minimise them. It will answer questions such as what to do in the case of a small fuel spillage and what detergents to use on board, as well as encourages boat users to think about 'how green is my boating'? To find out more, go to www.thegreenblue.org.uk



Oil

9.1 Engine/gearbox oil leak collection

In general, it is better to maintain engines so that they do not leak oil and fuel. However, any leaks and drips which do develop, must be contained and prevented from running into other sections of the boat (this may also pose a fire hazard from unseen accumulation), or overboard causing waterway pollution.

Even regularly maintained engine and gearbox installations can leak.

When oil leaks from your engine(s) or gearbox(es), oil or oil soaked debris can build up within the engine space and become a fire hazard as well as increase the risk of pollution linked to emptying the bilges.

9.1.1/R REQUIREMENT

Will all oil leaks from the engine/s or gearbox(es) be collected in an engine tray or oil-tight area?

Check for the presence and condition of an engine tray or oil-tight area under all fixed internal combustion engines and gearboxes.

Estimate the volume of any engine tray and the capacity of the protected engine and gearbox.

All fixed internal combustion engine and gearbox installations must have an engine tray or oil-tight area.

Each engine tray or oil-tight area must be at least as long and as wide as the combined length/width of the engine and gearbox.

The material of each engine tray or oil-tight area must be non-porous and oil resistant.

All engine trays or oil-tight areas, including joints and seams, must be free of signs of leaks, damage and deterioration.

The volume of each engine tray or oil-tight area must be sufficient to retain the estimated capacity of the engine/gearbox sumps.

Note – Oil-tight areas must collect from within the engine/gearbox space and must not extend into other parts of the vessel.

If you cannot introduce an oil-tight area or you have fixed bilge pumps that will draw from an area with the potential for oil to mix with water, you must prevent the avoidable discharge of oily water into the waterway. We outline two acceptable routes for fixed bilge pumps.

9.1.2/R REQUIREMENT

Does the bilge pumping system minimise the risk of avoidable pollution?

Check for presence of a fixed bilge pump or fixed bilge suction pipe within an engine tray or oil-tight area.

If present, check for the presence of a bilge water filter installed in the overboard discharge line or the facility to discharge to a holding tank.

If a bilge water filter is present, verify the discharge level performance by examining any markings on the filter. If necessary, have an appropriate declaration from the manufacturer or supplier available.

Fixed bilge pumps and bilge suction pipes must not draw from an engine tray or oil-tight area, unless the:

- discharge is through a bilge water filter capable of a 5 parts per million discharge performance level, as verified by markings on the filter or an appropriate declaration from the manufacturer or supplier; or,
- discharge line is connected to a holding tank.

Notes – Portable bilge pumps or bilge suction pipes should not be used within an engine tray or oil-tight area. Discovery during a BSS examination of such usage will prompt advice.

Where the discharge performance level of a bilge water filter cannot be verified, the filter will be considered as non-compliant until the performance level is verifiable. You will need to provide manufacturer's or supplier's supporting paperwork on request.

If a significant quantity of fuel is found to be escaping, a warning notice will be issued and the navigation or harbour authority informed.

Best practice

Check regularly for signs of oil outside the oil-tight area. If found and there is no pump-out protection, please check the arrangements to keep the general bilge area oil-tight. If they are not effective, the boat does not comply with the Requirements.

b

Information:

If large quantities of fuel or other substances escape into a waterway you should contact the Environment Agency or the Scottish Environment Protection Agency Pollution Hotline on 0800 80 70 60 (24hrs).



Sewage

9.2 Sanitation systems

Any sewage discharge into a waterway is offensive and is prohibited by law on most inland waterways. Here we examine the risk of a boat's toilet system creating pollution.

If your boat's toilet system is capable of discharging overboard directly into the waterway, you must guard against this happening.

9.2.1/R REQUIREMENT

Is a valve fitted in the discharge line of any toilet appliance or holding tank with overboard discharge?

Check all toilets and holding tanks for the presence of an overboard discharge line.

If present, check for the presence and condition of a valve installed in the discharge line.

All toilets and holding tanks systems having an overboard discharge line must have a valve fitted in the discharge line.

The valve and connections must be complete and leak-free.

Notes – Diverter valves to holding tanks not capable of being discharged overboard are compliant.

Discharge outlets having a 'tools-to-remove' cap, or overboard discharge lines from holding tanks discharged solely by shore-side pumping arrangements, are both compliant.

If toilet waste is found to be escaping into the watercourse from your boat, your navigation or harbour authority will be informed. If your boat's sanitation arrangements inevitably result in any toilet waste discharging overboard, please contact the BSS Office.



Best practice

Closed toilet-systems help protect our waterways. If you are fitting a holding tank for quayside pump-out, we recommend the system complies with standard BS EN ISO 8099. It is important that the pump-out deck fitting be manufactured precisely in accordance with the dimensions prescribed to ensure an effective connection during pump-out. A further back-up seal can be provided by some deck fittings.

To avoid risk of tank collapse or implosion during pump-out, we also recommend holding tank vent pipes have a minimum 38mm (1½ in) internal diameter.



Information

Owners of boats based in, or visiting, an inland waterway are advised to check with the relevant navigation authority concerning any restriction in place in respect of sea toilets capable of discharging directly overboard. Examiners are not required to render sea toilets inoperable. However, some navigation authorities require owners to inform them of the presence of sea toilets.